

SUGGESTED SPECIFICATIONS (1 of 2)

M&H FLUSH TYPE FIRE HYDRANTS

◆ Style 229—5 ¼” V.O.

GENERAL

Flush Type Fire Hydrants shall comply, where applicable, to AWWA Standard C-502, latest revision. Flush Type Fire Hydrants shall be of the compression type, with the main valve opening against the pressure and closing with the pressure. The main valve opening shall be 5 ¼” diameter. Flush Type Fire Hydrants shall be of a dry barrel design.

RATING

Flush Type Fire Hydrants shall be rated at 150 psi water working pressure, tested at 300 pounds hydrostatic for structural soundness in the following manner; 300 pound hydrostatic test supplied from the inlet side, first with the main valve closed for the testing of the valve seat; second, with the main valve open for testing of the drain valves and the hydrant barrel.

END

Hydrants shall be connected to the main by a 6” mechanical joint or flanged shoe. Mechanical joint shoes shall be fitted with strapping lugs.

DESIGN

Hydrants shall be constructed of ASTM A-126 Class B cast iron. The main valve of the hydrant shall be made of rubber.

The bottom stem threads of the main valve rods shall be fitted with a cap nut for sealing the threads away from the water.

Changes in size or shape of the waterway shall be accomplished by means of easy curves. Exclusive of the main valve opening, the net area of the waterway of the barrel and the foot piece at the smallest part shall not be less than 120% of that of the net opening of the main valve.

Hose and pumper caps shall be individually chained to the hydrant.

The operating threads of the hydrant shall be so designed as to avoid the working of any iron or steel parts against either iron or steel. The operating stem and operating nut threads shall be square or acme type.

Bonnet shall be weather proof, free draining, and of a type that will maintain the operating mechanism in readiness for use under freezing conditions.

The operating nut shall be provided with a convenient means to afford lubrication to insure ease of operating and the prevention of wear and corrosion. Hydrants shall be of dry barrel type. Hydrant shoe shall have two positive acting non-corrodible drain valves that shall drain the hydrant completely by opening when the main valve is closed, and also to close tightly when the main valve is open.

All like parts of hydrants of the same size and model produced by the same manufacturer shall be interchangeable.

Hydrants shall open by turning to the (specify one (left or right)).

Threads on hose and steamer nozzles shall be National Standard unless otherwise specified.

Operating nuts and cap nuts shall conform to National Standard unless otherwise specified.

Bury shall be (specify depth of bury) measuring depth from grade line to bottom of connecting pipe.

SUGGESTED SPECIFICATIONS (1 of 2)

GENERAL

Auxiliary shut-off (isolation) gate valves shall be of the same manufacturer as the hydrant when required.

Hydrant Assembly shall include a cast iron box and cover for installation flush with grade level.

The hydrant box shall not be attached to the hydrant at any point thus prohibiting loads from being transferred to the hydrant, standpipe, or connecting pipe.

Hydrant box, when properly installed with cover shall withstand a 25,000 pound load.

Hydrants shall have 2-2 ½" hose connections and 1-4 ½" steamer nozzle.

COATING

The inside of all hydrants shall be coated in accordance with AWWA standards except for bronze and machined surfaces. Exterior on hydrant nozzle section shall be painted Fire Hydrant Red (or as specified).

Hydrant shoe shall have protective, thermosetting epoxy coating applied inside and out before assembly. Prior to application of coating. Shoe shall be mechanically and chemically cleaned in compliance with SSPC Standards SP-5 and SP-8. Average dry film thickness of 5 mils shall be applied on interior and exterior surfaces of hydrant shoe. Coating designation to be M0601 epoxy and conform fully to AWWA C550-81, Section 3.

MARKINGS

Hydrants shall be marked with name of manufacturer, year of manufacture, and size

M&H Flush Type Hydrants are for use where traffic model hydrants protruding above ground might interfere with traffic in such places as airport runways and industrial areas. May be set in vaults or can be supplied with cast iron box and cover. This flush type hydrant sits completely underground and is accessible by simply lifting the box cover. Internal parts of the hydrant are exactly the same as the M&H 129 hydrant.

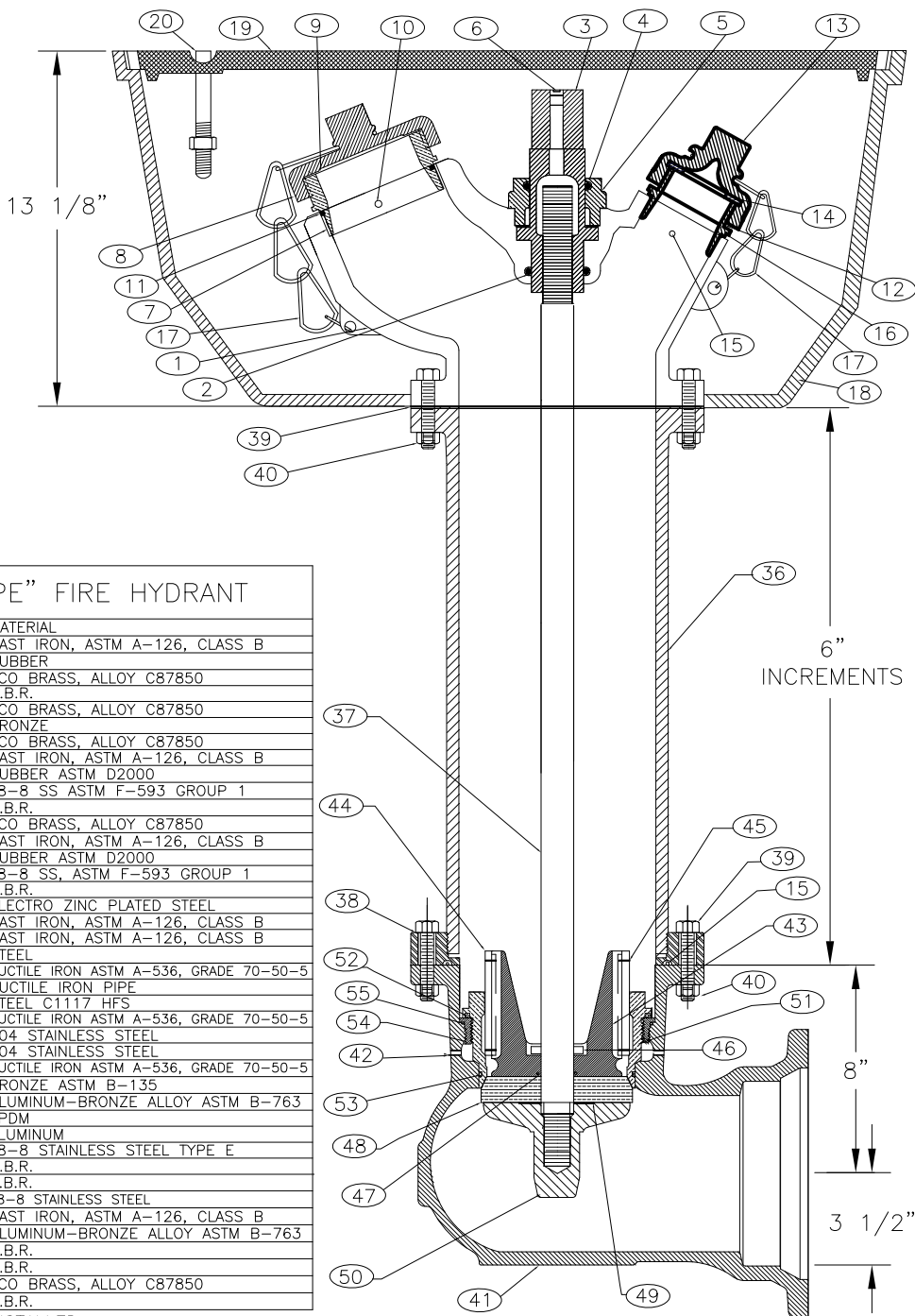

M&H MODEL 229 "FLUSH TYPE" FIRE HYDRANT

ITEM#	QTY	DESCRIPTION	MATERIAL
1	1	NOZZLE SECTION	CAST IRON, ASTM A-126, CLASS B
2	1	OP NUT O-RING SEAL	RUBBER
3	1	OPERATING NUT	ECO BRASS, ALLOY C87850
4	1	HOLD DOWN NUT "O" RING	N.B.R.
5	1	HOLD DOWN NUT	ECO BRASS, ALLOY C87850
6	1	LUBRICATING PLUG	BRONZE
7	1	PUMPER NOZZLE 4 1/2	ECO BRASS, ALLOY C87850
8	1	PUMPER NOZZLE CAP	CAST IRON, ASTM A-126, CLASS B
9	1	PUMPER NOZZLE CAP GASKET	RUBBER ASTM D2000
10	1	PUMPER NOZZLE SET SCREW	18-8 SS ASTM F-593 GROUP 1
11	1	PUMPER NOZZLE "O" RING	N.B.R.
12	2	HOSE NOZZLE 2 1/2	ECO BRASS, ALLOY C87850
13	2	HOSE NOZZLE CAP	CAST IRON, ASTM A-126, CLASS B
14	2	HOSE NOZZLE CAP GASKET	RUBBER ASTM D2000
15	2	HOSE NOZZLE SET SCREW	18-8 SS, ASTM F-593 GROUP 1
16	2	HOSE NOZZLE "O" RING	N.B.R.
17	-	NOZZLE CAP CHAINS	ELECTRO ZINC PLATED STEEL
18	1	HYDRANT BOX	CAST IRON, ASTM A-126, CLASS B
19	1	HYDRANT BOX COVER	CAST IRON, ASTM A-126, CLASS B
20	1	HYDRANT BOX COVER HANDLE	STEEL
35	*1	STAND PIPE UPPER FLANGE	DUCTILE IRON ASTM A-536, GRADE 70-50-5
36	1	STAND PIPE	DUCTILE IRON PIPE
37	1	MAIN VALVE ROD	STEEL C1117 HFS
38	*1	STAND PIPE LOWER FLANGE	DUCTILE IRON ASTM A-536, GRADE 70-50-5
39	16	SHOE/NOZZLE BOLTS 5/8-11 X 3 1/2	304 STAINLESS STEEL
40	16	SHOE/NOZZLE NUTS 5/8-11	304 STAINLESS STEEL
41	1	HYDRANT SHOE/ELBOW	DUCTILE IRON ASTM A-536, GRADE 70-50-5
42	2	DRAIN HOLE BUSHINGS	BRONZE ASTM B-135
43	1	UPPER DRAIN VALVE/UPPER VALVE PLATE	ALUMINUM-BRONZE ALLOY ASTM B-763
44	2	DRAIN VALVE FACINGS	EPDM
45	8	DRAIN VALVE FACING RIVETS	ALUMINUM
46	1	LOWER STEM PIN 1/2 X 1 3/4	18-8 STAINLESS STEEL TYPE E
47	1	LOWER STEM "O" RING SEAL	N.B.R.
48	1	MAIN VALVE RUBBER/SEAT	S.B.R.
49	1	LOWER VALVE PLATE LOCKWASHER	18-8 STAINLESS STEEL
50	1	LOWER VALVE PLATE/BOTTOM PLATE	CAST IRON, ASTM A-126, CLASS B
51	1	BRONZE MAIN VALVE SEAT RING	ALUMINUM-BRONZE ALLOY ASTM B-763
52	1	MAIN VALVE SEAT RING UPPER "O" RING	N.B.R.
53	1	MAIN VALVE SEAT RING LOWER "O" RING	N.B.R.
54	*1	SHOE RETAINER RING	ECO BRASS, ALLOY C87850
55	*1	SHOE RETAINER RING "O"-RING	N.B.R.

* NOT FIELD REPLACEABLE - PERMANENTLY INSTALLED
 BURY EXAMPLE: 4 FOOT BURY HYDRANT HAS 24" STANDPIPE

MAIN VALVE SIZES AVAILABLE: 5 1/4"

250 PSI WORKING PRESSURE
 500 PSI HYDROSTATIC TEST PRESSURE

HYDRANT SHOE STYLES AVAILABLE:
 6" - MECHANICAL JOINT
 6" - FLANGED

M&H VALVE COMPANY
 ANNISTON, ALABAMA
 A DIVISION OF MCWANE INC.

DWN: KLM
 DATE: 11/2014
 DWG. NO.
 FH-229

M&H Flush Type Hydrants are for use where traffic model hydrants protruding above ground might interfere with traffic in such places as airport runways and industrial areas. May be set in vaults or can be supplied with cast iron box and cover. This flush type hydrant sits completely underground and is accessible by simply lifting the box cover. Internal parts of the hydrant are exactly the same as the M&H 129 hydrant.

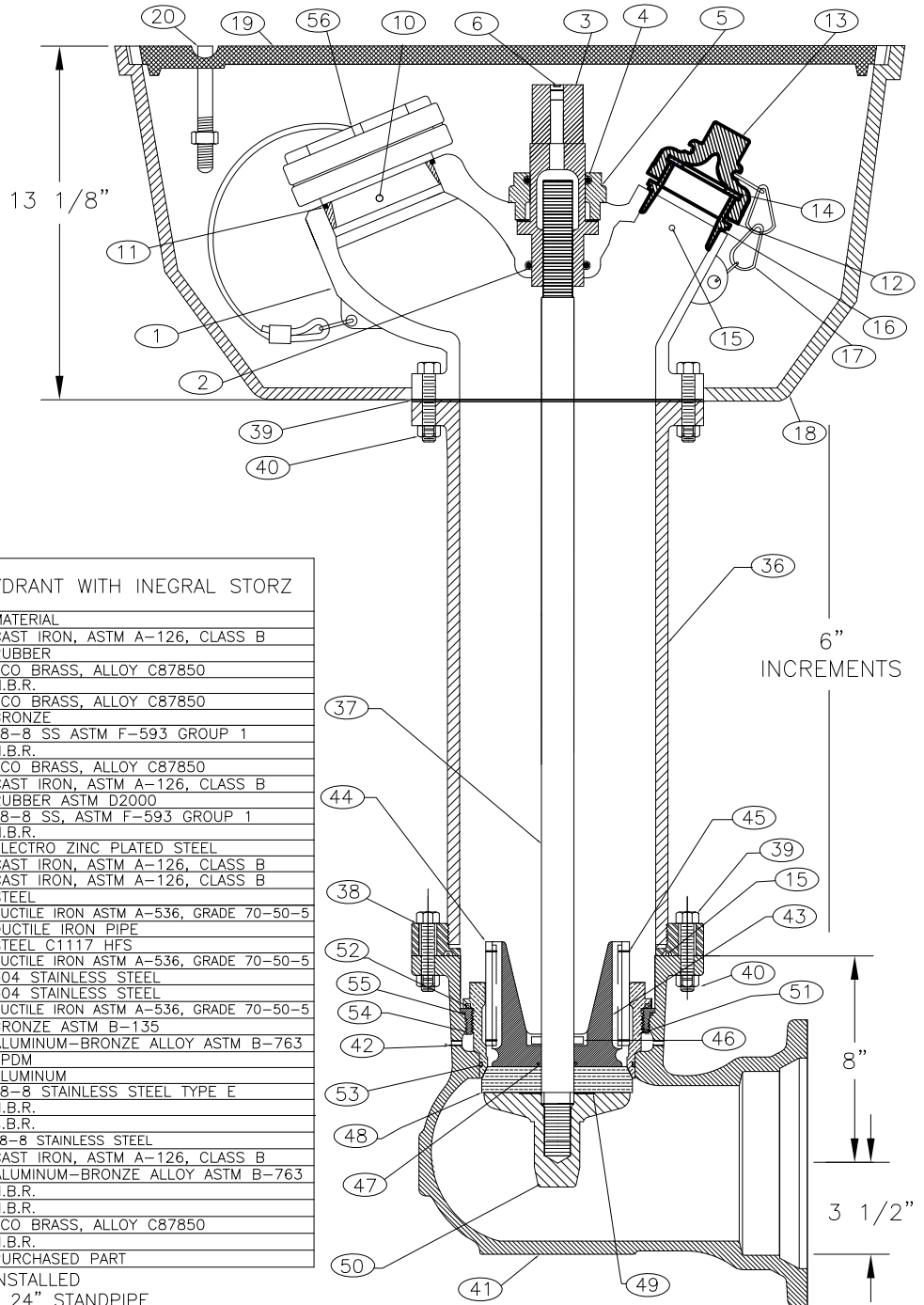

M&H MODEL 229 "FLUSH TYPE" FIRE HYDRANT WITH INTEGRAL STORZ

ITEM#	QTY	DESCRIPTION	MATERIAL
1	1	NOZZLE SECTION	CAST IRON, ASTM A-126, CLASS B
2	1	OP NUT O-RING SEAL	RUBBER
3	1	OPERATING NUT	ECO BRASS, ALLOY C87850
4	1	HOLD DOWN NUT "O" RING	N.B.R.
5	1	HOLD DOWN NUT	ECO BRASS, ALLOY C87850
6	1	LUBRICATING PLUG	BRONZE
10	1	PUMPER NOZZLE SET SCREW	18-8 SS ASTM F-593 GROUP 1
11	1	PUMPER NOZZLE "O" RING	N.B.R.
12	2	HOSE NOZZLE 2 1/2	ECO BRASS, ALLOY C87850
13	2	HOSE NOZZLE CAP	CAST IRON, ASTM A-126, CLASS B
14	2	HOSE NOZZLE CAP GASKET	RUBBER ASTM D2000
15	2	HOSE NOZZLE SET SCREW	18-8 SS, ASTM F-593 GROUP 1
16	2	HOSE NOZZLE "O" RING	N.B.R.
17	-	NOZZLE CAP CHAINS	ELECTRO ZINC PLATED STEEL
18	1	HYDRANT BOX	CAST IRON, ASTM A-126, CLASS B
19	1	HYDRANT BOX COVER	CAST IRON, ASTM A-126, CLASS B
20	1	HYDRANT BOX COVER HANDLE	STEEL
35	*1	STAND PIPE UPPER FLANGE	DUCTILE IRON ASTM A-536, GRADE 70-50-5
36	1	STAND PIPE	DUCTILE IRON PIPE
37	1	MAIN VALVE ROD	STEEL C1117 HFS
38	*1	STAND PIPE LOWER FLANGE	DUCTILE IRON ASTM A-536, GRADE 70-50-5
39	16	SHOE/NOZZLE BOLTS 5/8-11 X 3 1/2	304 STAINLESS STEEL
40	16	SHOE/NOZZLE NUTS 5/8-11	304 STAINLESS STEEL
41	1	HYDRANT SHOE/ELBOW	DUCTILE IRON ASTM A-536, GRADE 70-50-5
42	2	DRAIN HOLE BUSHINGS	BRONZE ASTM B-135
43	1	UPPER DRAIN VALVE/UPPER VALVE PLATE	ALUMINUM-BRONZE ALLOY ASTM B-763
44	2	DRAIN VALVE FACINGS	EPDM
45	8	DRAIN VALVE FACING RIVETS	ALUMINUM
46	1	LOWER STEM PIN 1/2 X 1 3/4	18-8 STAINLESS STEEL TYPE E
47	1	LOWER STEM "O" RING SEAL	N.B.R.
48	1	MAIN VALVE RUBBER/SEAT	S.B.R.
49	1	LOWER VALVE PLATE LOCKWASHER	18-8 STAINLESS STEEL
50	1	LOWER VALVE PLATE/BOTTOM PLATE	CAST IRON, ASTM A-126, CLASS B
51	1	BRONZE MAIN VALVE SEAT RING	ALUMINUM-BRONZE ALLOY ASTM B-763
52	1	MAIN VALVE SEAT RING UPPER "O" RING	N.B.R.
53	1	MAIN VALVE SEAT RING LOWER "O" RING	N.B.R.
54	*1	SHOE RETAINER RING	ECO BRASS, ALLOY C87850
55	*1	SHOE RETAINER RING "O"-RING	N.B.R.
56	1	INTEGRAL STORZ WITH CABLE	PURCHASED PART

* NOT FIELD REPLACEABLE - PERMANENTLY INSTALLED
 BURY EXAMPLE: 4 FOOT BURY HYDRANT HAS 24" STANDPIPE

MAIN VALVE SIZES AVAILABLE: 5 1/4"

250 PSI WORKING PRESSURE
 500 PSI HYDROSTATIC TEST PRESSURE

HYDRANT SHOE STYLES AVAILABLE:
 6" - MECHANICAL JOINT
 6" - FLANGED

<p>M&H VALVE COMPANY ANNISTON, ALABAMA A DIVISION OF MCWANE INC.</p>	DWN: KLM
	DATE: 11/2014
	DWG. NO. FH-229-ISZ