

GENERAL

M&H AWWA C508 STANDARD SWING CHECK VALVES

- ◆ Style 59-02 plain / 159-Lever & Weight / 259-02 Lever & Spring
- ◆ Sizes 2" Through 36"
- ◆ Water / Sewage Service

M&H Swing Check valves are widely specified by engineers and operating personnel. They are well proportioned and sturdily constructed - provide the ideal answer wherever check valves are needed in water and waste treatment plants.

The valve clapper swings open to allow a "Full Waterway Flow" through the valve equal to the nominal diameter of the pipe. The clapper operates freely and opens or closes in accordance with the direction of flow. Clappers for valves 2", 2.5", and 3" are bronze. Clappers for valves 4" through 12" are cast iron, bronze-faced. Rubber faced clappers are available on all check valves 2 ½" thru 12" and standard on 14" through 36". For optimum performance, rubber faced clappers are recommended on all check valves 14" and larger.

Three types of M&H Check Valves are manufactured. First, the plain swing check valve which opens by line pressure and flow, and closes by gravity under a no flow condition; the clapper is lowered when the flow drops or reverses direction. The second type is outside lever-and-weight and the third type is outside lever-and-spring. These refinements are desirable to accomplish quicker closing and to minimize slamming where conditions of rapid flow reversal are encountered.

Plain, Lever and Weight, and Lever and Spring designs can be used for vertical installation. Lever-and-weight type check valves for horizontal installations require the lever arm close to parallel to the run of the pipe and the weight on the downstream side of the clapper for quick closing. For vertical installation of lever-and-weight valves, the lever arm is moved to a position perpendicular to the run of the pipe, to assist in closing.

Either lever-and-weight or lever-and-spring check valves are adjustable. Both types require field adjustment to best meet particular operating conditions. Unless otherwise ordered, the lever-and-weight or the lever-and-spring is placed on the right hand side when facing the valve inlet. Under conditions of extreme rapid flow reversal, check valves with dual lever arms can be supplied.

Stainless steel hinge pins are featured in all sizes. Check Valves 2"-12" have O-ring sealed side plugs. Levered valves use a fiber packing in its gland housing. Lever-and-weight or lever-and-spring type check valves sizes 14" through 36" using packing are regularly supplied with hinge pin extended through bronze bushing and with outside glands and rubber faced clappers. Alemite fittings for lubrication of bronze bushing can be supplied in either design when specified.

All check valves have bosses on sides and bottom that may be tapped for draining or used for by-pass. When tapping is required, refer to the table that shows the maximum tap size for the boss locations. Built up bypasses can be furnished on check valves, sizes 14" and smaller. Larger sizes can be supplied with flange type bypasses.

Flanged end, increasing check valves are also available in plain, lever-and-spring or lever-and-weight configurations. These valves provide size reduction and eliminate requirements for special adapters or fittings. Increasing check valves are most often used on pump discharge outlets such as package lift stations.

Note: When lever-and-weight or lever-and-spring check valves are to be specified or used, we recommend lever-and-spring over lever-and-weight for all 14" and larger. In addition, rubber faced clappers should be used. As stated in AWWA C508, "Conditions of water hammer, hydraulic pulsation, and excessive operating noise are results of system design rather than valve design and are beyond the scope of this standard and require special design and construction considerations."

Note:

It is generally recommended that when using M&H swing check valves that you locate the valve at least 5 pipe diameters downstream from any flow disturbance or obstruction (valve, pump, elbow, reducer, etc.). Turbulence close to the check valve may result in valve "chatter" resulting in premature failure of the check valve.

As stated in AWWA C508, "Conditions of water hammer, hydraulic pulsation, and excessive operating noise are results of system design rather than valve design and are beyond the scope of this standard and require special design and construction considerations."

STYLE NUMBERS (2"-36")

M&H AWWA C508 STANDARD SWING CHECK VALVES

Size Range	Water Working Pressure psi	Seat Test Psi	Hydrostatic Shell Test psi
AWWA 2" – 12"	200	400	400
AWWA 14"-36"	150	300	300

Type / Facing Material / Options	Size Range	Style Number	Drawing Number
----------------------------------	------------	--------------	----------------

2"-12" STANDARD CHECKS

Plain / Swing Check---Rubber Faced	2"-12"	59-02A	CV-A1-PC
Plain / Swing Check---Rubber Faced—With Tapped Cover	2"-12"	59-02AT	CV-A1-PC
Plain / Swing Check---Bronze Faced	2"-12"	59-02	CV-A1-PC
Plain / Swing Check ---Bronze Faced—With Tapped Cover	2"-12"	59-02T	CV-A1-PC
Lever & Weight—Rubber Faced	2"-12"	159-02A	CV-A1-LW
Lever & Weight—Rubber Faced—With Limit Switch	2"-12"	159-02ALS	CV-A1-LW
Lever & Weight—Rubber Faced—With Dual Arm	6"-12"	159-02AD	CV-A1-LW
Lever & Weight—Bronze Faced	2"-12"	159-02	CV-A1-LW
Lever & Weight—Bronze Faced—With Limit Switch	2"-12"	159-02LS	CV-A1-LW
Lever & Weight—Bronze Faced—With Dual Arm	6"-12"	159-02D	CV-A1-LW
Lever & Spring—Rubber Faced	2"-12"	259-02A	CV-A1-LS
Lever & Spring—Rubber Faced—With Limit Switch	2"-12"	259-02ALS	CV-A1-LS
Lever & Spring—Bronze Faced	2"-12"	259-02	CV-A1-LS
Lever & Spring—Bronze Faced—With Limit Switch	2"-12"	259-02LS	CV-A1-LS

14"-36" STANDARD CHECKS

Plain / Swing Check---Rubber Faced	14"-36"	59-02A	LCV-A1
Lever & Weight—Rubber Faced	14"-36"	159-02A	LCV-A1
Lever & Weight—Rubber Faced—With Limit Switch	14"-36"	159-02ALS	LCV-A1
Lever & Weight—Rubber Faced—With Dual Arm	14"-36"	159-02AD	LCV-A1
Lever & Spring—Rubber Faced	14"-36"	259-02A	LCV-A1
Lever & Spring—Rubber Faced—With Limit Switch	14"-36"	259-02ALS	LCV-A1
Lever & Spring—Rubber Faced—With Dual Arm	14"-36"	259-02AD	LCV-A1

Note: In addition to Dual Arms, Limit Switches & Tapped Cover, M&H also can provide check valves with special coatings and tapped bosses. See drawing CV-TB for location and sizes of tapped bosses.

Note:

It is generally recommended that when using M&H swing check valves that you locate the valve at least 5 pipe diameters downstream from any flow disturbance or obstruction (valve, pump, elbow, reducer, etc.). Turbulence close to the check valve may result in valve "chatter" resulting in premature failure of the check valve.

As stated in AWWA C508, "Conditions of water hammer, hydraulic pulsation, and excessive operating noise are results of system design rather than valve design and are beyond the scope of this standard and require special design and construction considerations."

SUGGESTED SPECIFICATIONS

M&H AWWA C508 STANDARD SWING CHECK VALVES

- ◆ Style 59-02 plain / 159-Lever & Weight / 259-02 Lever & Spring
- ◆ Sizes 2” Through 36”
- ◆ Water / Sewage Service

GENERAL Check Valves shall be all iron body, bronze mounted, full opening swing type. Valve clapper shall swing full open permitting a “full flow” thru the valve equal to the nominal pipe diameter. They shall comply with AWWA Standard C-508 latest revision.

RATING Check Valves (2” through 12”) shall be rated at 200 psi water working pressure, 400 psi hydrostatic test for structural soundness. Check valves (14” through 36”) shall be rated at 150 psi water working pressure, 300 psi hydrostatic test. Seat tightness at rated working pressure shall be in accordance with values shown in AWWA Standard C-500 for gate valve and fully conform to AWWA C508.

END CONFIGURATION Check Valves shall be furnished with 125# ANSI flanged end connections.

MATERIALS All cast iron shall conform to ASTM-A-126 Class B. Casting shall be clean and sound without defects that will impair their service.

Clappers 2”-3” shall be bronze.
Clappers 4”-12 shall be faced with bronze or rubber.
Clappers 14”-36” shall be rubber faced.

Body Rings / Seats shall be bronze.

Hinge pins shall be 18-8 stainless steel with bronze side plugs.

DESIGN Check Valves shall be constructed to permit top entry for complete removal of internal components without removing the valve from the line.

Plain Check Valves 2”-12” shall have O-ring sealed side plugs.
Levered Check Valves in all sizes shall have conventional packing & packing gland design.

When specified, for application conditions of rapid flow reversal or vertical installation, check valve shall be equipped with adjustable outside lever & spring or lever & weight to accomplish faster closing and to minimize slamming effect.

Bosses shall be provided on check valves which may be tapped for draining or used for by-pass. When tapping is required, boss designation and size of tap should be stated. Refer to drawing CV-TB for boss options

All valves 14” and larger shall have extended hinge pins for future addition of levers and springs if required. Valves shall be suitable for installation in either horizontal or vertical position.

COATING The inside and outside of all valves, together with the working parts except bronze and machined surfaces, shall be coated in accordance with AWWA standards.

MARKINGS Markings shall be in accordance with AWWA C-508 and shall include size, working pressure, and cast arrow to indicate direction of flow, name of manufacturer, and year of manufacture.

Note:

It is generally recommended that when using M&H swing check valves that you locate the valve at least 5 pipe diameters downstream from any flow disturbance or obstruction (valve, pump, elbow, reducer, etc.). Turbulence close to the check valve may result in valve “chatter” resulting in premature failure of the check valve.

September 1, 2012 / C508 Check Valves

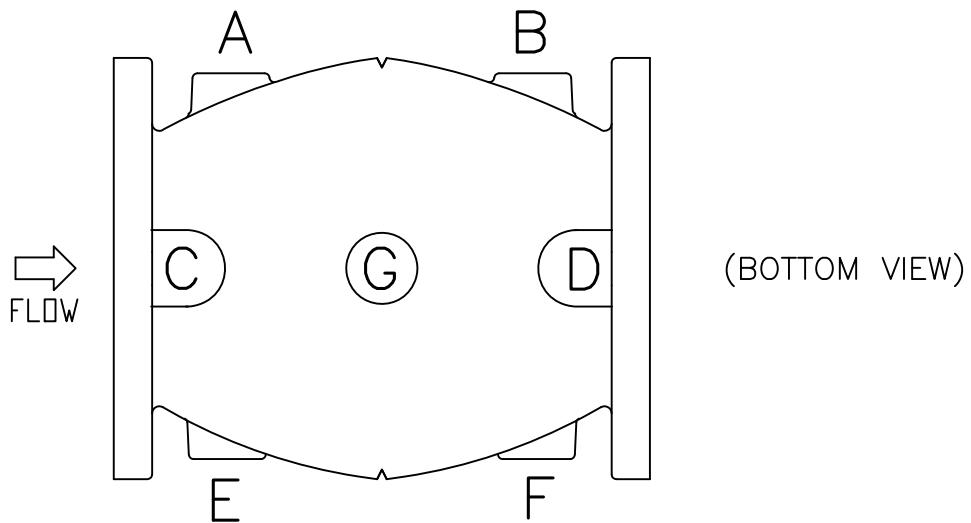
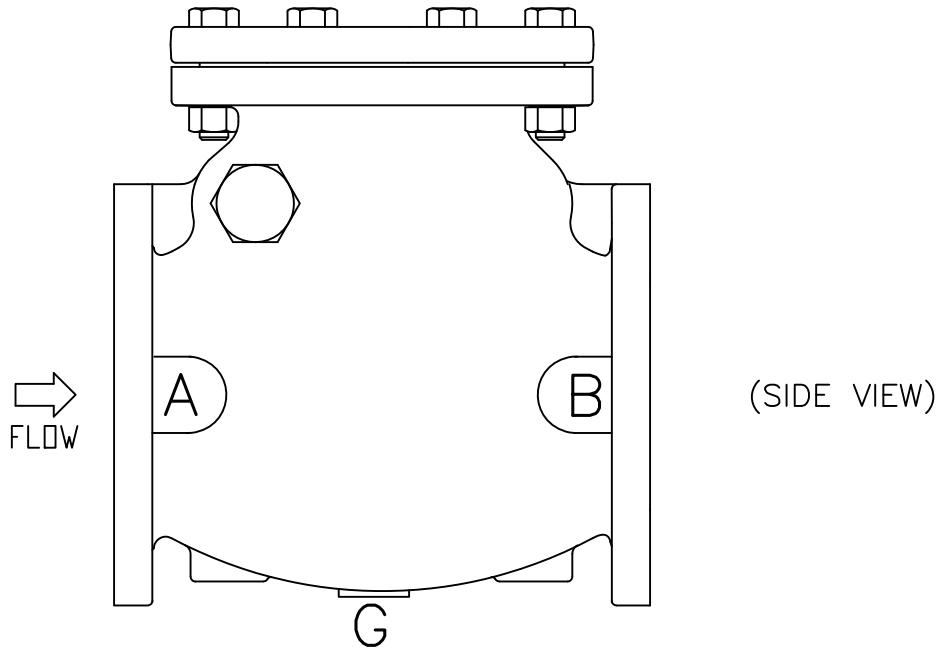

When ordering Check Valves tapped for bypass or drain, specify exact location and size of tap using letters above for boss designation. These locations of drain and by-pass tappings conform to the Manufacturers Standardization Society Specification SP-45-1953

AWWA SWING CHECK VALVES MAXIMUM TAP SIZE FOR BOSS LOCATIONS							
SIZE	A	B	C	D	E	F	G
2	0.75	0.75	0.75	NA	NA	NA	NA
2.5	0.75	0.75	0.75	NA	0.75	0.75	NA
3	0.75	0.75	0.75	NA	0.75	0.75	NA
4	1	1	1.25	1.25	1	1	NA
6	1.25	1.25	1.25	1.25	1.25	1.25	NA
8	2	2	1.25	1.25	2	2	0.75
10	2	2	1.25	1.25	2	2	0.75
12	2	2	1.25	1.25	2	2	0.75

M&H VALVE COMPANY
ANNISTON, ALABAMA
A DIVISION OF MCWANE INC.

DWN: TRIJ
DATE: 9/1/12
DWG. NO.
CV-TB

2" THRU 12"
SWING CHECK VALVES (ALL STYLES)
AWWA C508
LOCATION AND DIMENSIONS OF
TAPPING BOSSES

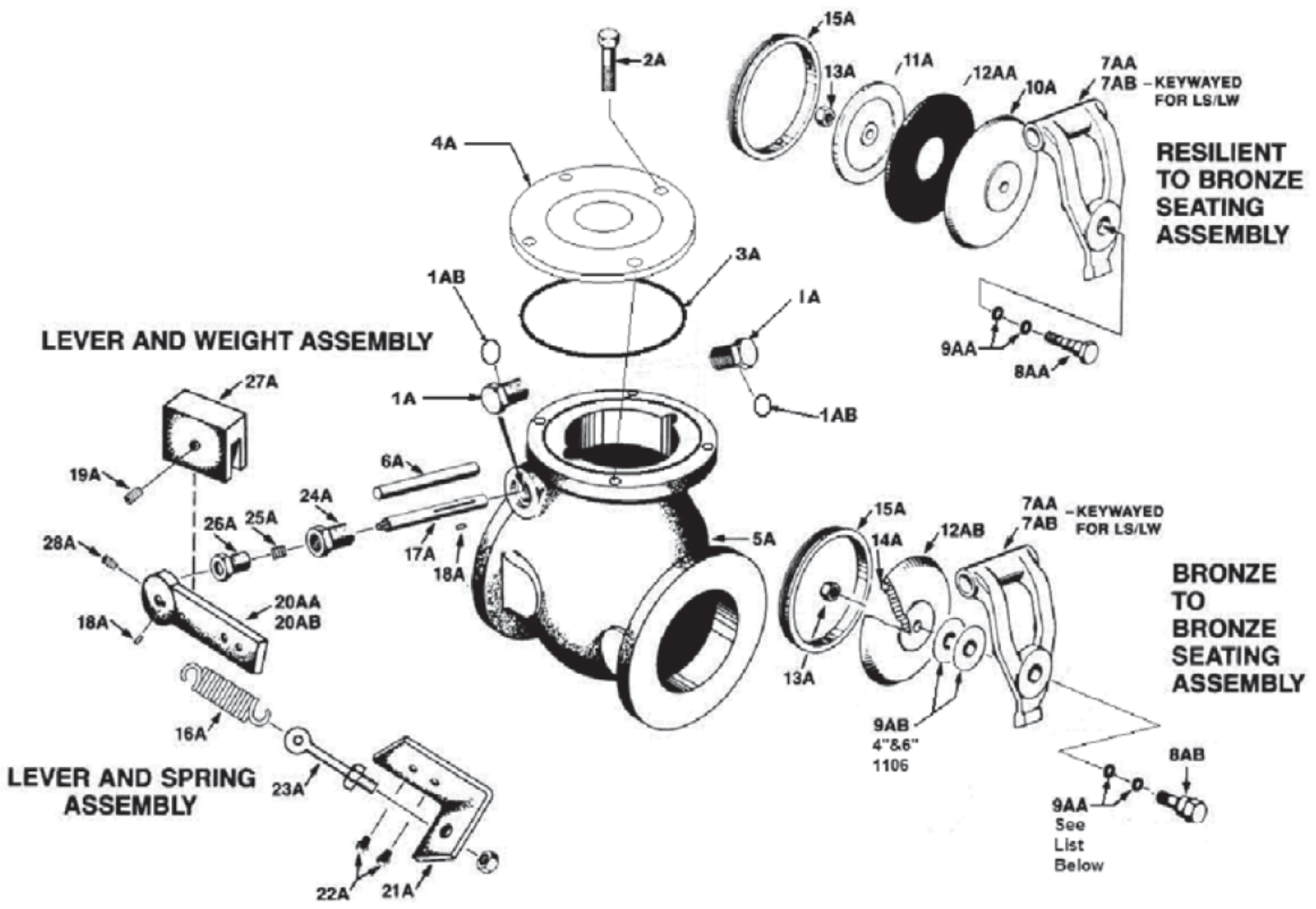

LEVER AND WEIGHT ASSEMBLY

RESILIENT TO BRONZE SEATING ASSEMBLY

BRONZE TO BRONZE SEATING ASSEMBLY

LEVER AND SPRING ASSEMBLY

9AA See List Below

9AB 4" x 8" 1106

KEYWAYED FOR LS/LW

KEYWAYED FOR LS/LW

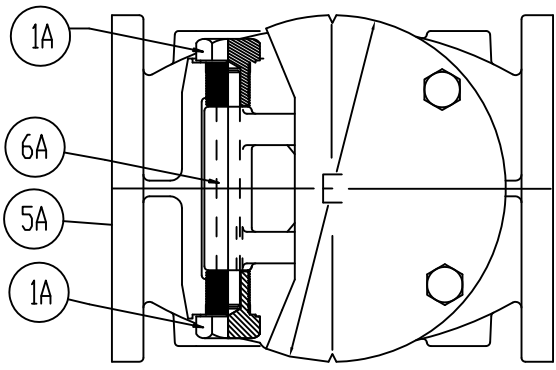

TAPPED COVER OPTION (VIEW 1)

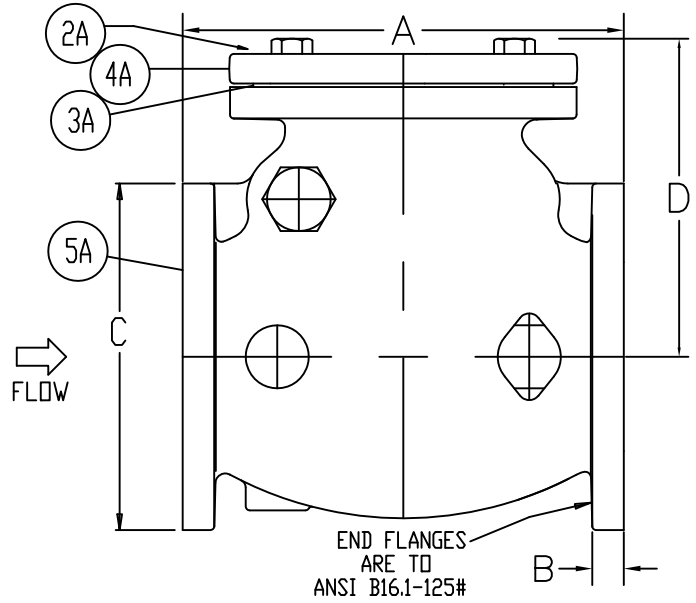
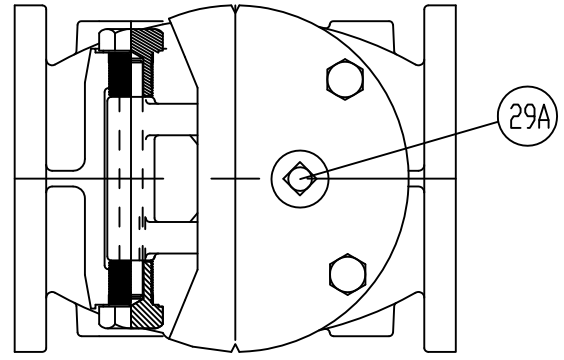

TAPPED COVER OPTION (VIEW 2)

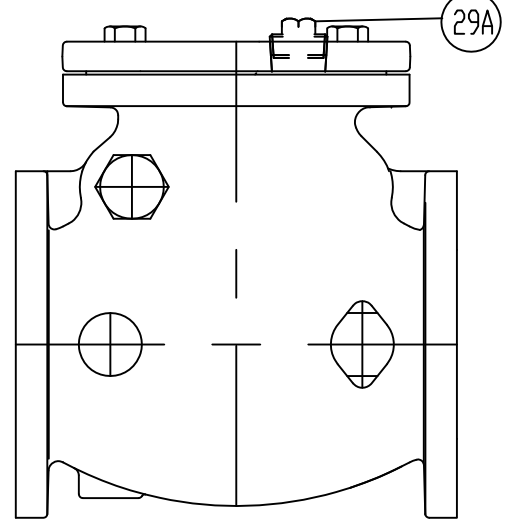

SIZE	A	B	C	D	E	WEIGHT
2	8	0.66	6	6	6	35
2 1/2	8.5	0.72	7	6.63	7	50
3	9.5	0.78	7.5	7.06	7.5	61
4	11.5	1.00	9	8.31	9	119
6	14	1.06	11	10.06	11	190
8	19.5	1.25	13.5	12.38	13.50	347
10	24.5	1.31	16	13.93	16.75	566
12	27.5	1.38	19	16.18	19	774

PART	QTY	DESCRIPTION	MATERIAL & ASTM SPEC.
1A	2	SIDE PLUG	BRONZE
2A	4	BOLTS	18-8 STAINLESS STEEL
3A	1	O-RING	BUNA-N
4A	1	CAP	CI A-126 CLASS B
5A	1	BODY	CI A-126 CLASS B
6A	1	HINGE PIN	304 STAINLESS STEEL A-276
29A	1	TAPERED PLUG (OPTIONAL)	STEEL

STYLE-59-02A 2"-12" WITH RUBBER FACED CLAPPER
 STYLE-59-02 2"-12" WITH BRONZE FACED CLAPPER
 STYLE-59-02AT 2"-12" WITH RUBBER FACED CLAPPER-TAPPED COVER
 STYLE-59-02T 2"-12" WITH BRONZE FACED CLAPPER-TAPPED COVER

<p>M&H VALVE COMPANY ANNISTON, ALABAMA A DIVISION OF MCWANE INC.</p>	DWN: TRIJ	<p>2" THRU 12" STANDARD / PLAIN SWING CHECK AWWA C508-STYLE 59-02 (PAGE 1 of 2)</p>
	DATE: 9/1/12	
	DWG. NO. CV-A1-PC	

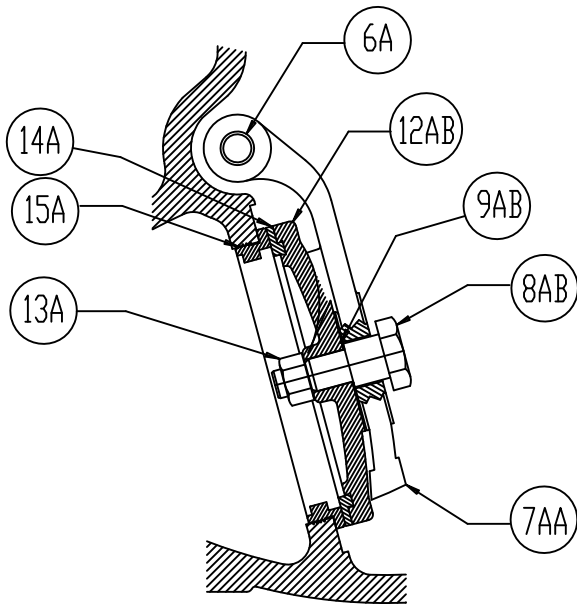

4'-12" PLAIN CHECK BRONZE SEATED DISC ASSEMBLY

6A	1	HINGE PIN	STAINLESS STEEL A-276 (304)
7AA	1	HINGE	DUCTILE IRON A-536
8AB	1	DISC BOLT	(4'-8") STEEL---(10'-12") BRONZE
9AB	2	DISC BOLT WASHER (4'-8")	
12AB	1	DISC	CAST IRON A-126 CLASS B
13A	1	DISC NUT	18-8 STAINLESS STEEL
14A	1	DISC RING	BRONZE
15A	1	SEAT RING	BRONZE

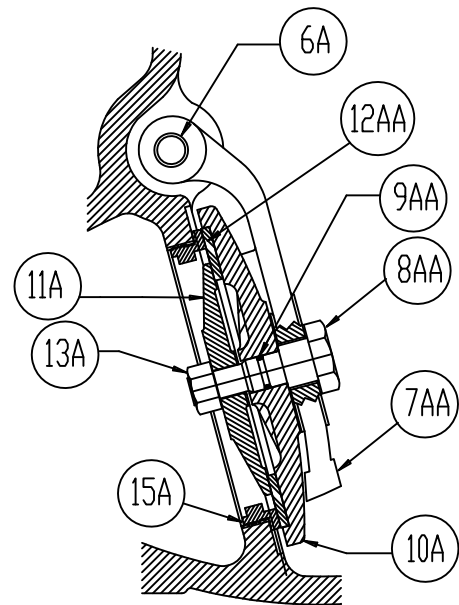

4'-12" PLAIN CHECK RESILIENT SEATED DISC ASSEMBLY

6A	1	HINGE PIN	STAINLESS STEEL A-276 (304)
7AA	1	HINGE	DUCTILE IRON A-536
8AA	1	DISC BOLT	(4'-8") STEEL---(10'-12") BRONZE
9AA	1	DISC BOLT O-RING (10',12")	SYNTHETIC RUBBER
10A	1	DISC HOLDER	CAST IRON A-126 CLASS B
11A	1	DISC PLATE	BRONZE
12AA	1	DISC	SYNTHETIC RUBBER
13A	1	DISC NUT	18-8 STAINLESS STEEL
15A	1	SEAT RING	BRONZE

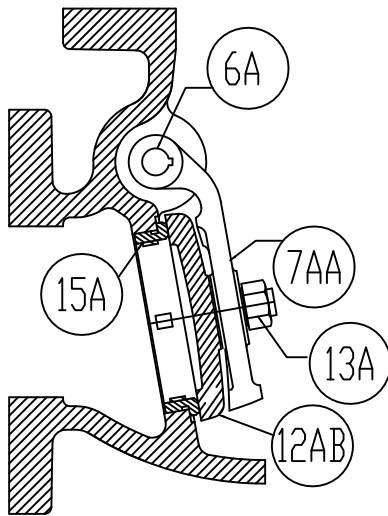

2'-3" PLAIN CHECK BRONZE SEATED DISC ASSEMBLY

6A	1	HINGE PIN	STAINLESS STEEL A-276 (304)
7AA	1	HINGE	BRONZE
12AB	1	DISC (WITH INTEGRAL DISC BOLT)	BRONZE
13A	1	DISC NUT	18-8 STAINLESS STEEL
15A	1	SEAT RING	BRONZE

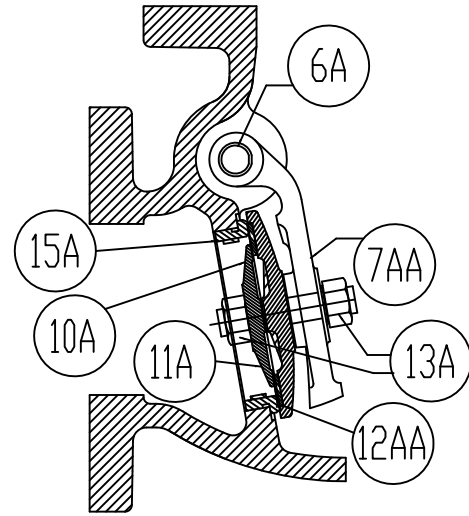

2'-3" PLAIN CHECK RESILIENT SEATED DISC ASSEMBLY

6A	1	HINGE PIN	STAINLESS STEEL A-276 (304)
7AA	1	HINGE	BRONZE
10A	1	DISC HOLDER (WITH INTEGRAL DISC BOLT)	BRONZE
11A	1	DISC PLATE	BRONZE
12AA	1	DISC	SYNTHETIC RUBBER
13A	2	DISC NUT	18-8 STAINLESS STEEL
15A	1	SEAT RING	BRONZE

M&H VALVE COMPANY
ANNISTON, ALABAMA
A DIVISION OF MCWANE INC.

DWN: TRIJ
DATE: 9/1/12
DWG. NO.
CV-A2-PC

2" THRU 12"
STANDARD / PLAIN SWING CHECK
AWWA C508-STYLE 59-02
(PAGE 2 of 2)

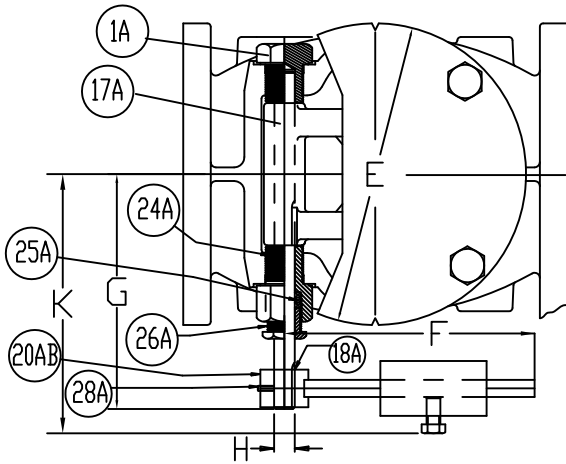

LIMIT SWITCH OPTION

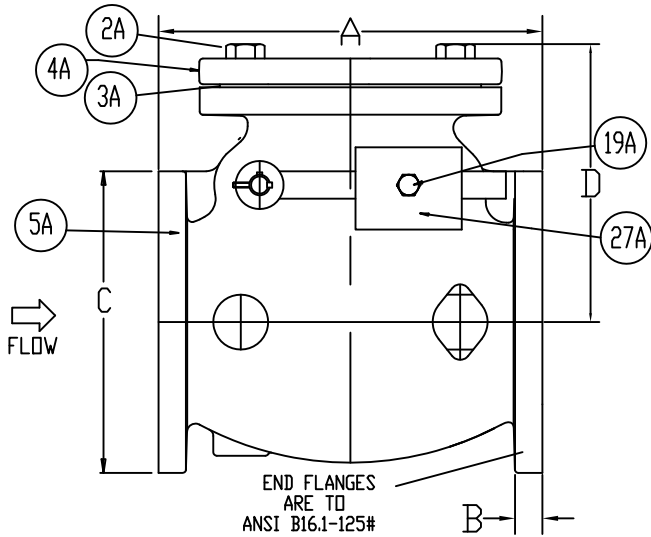
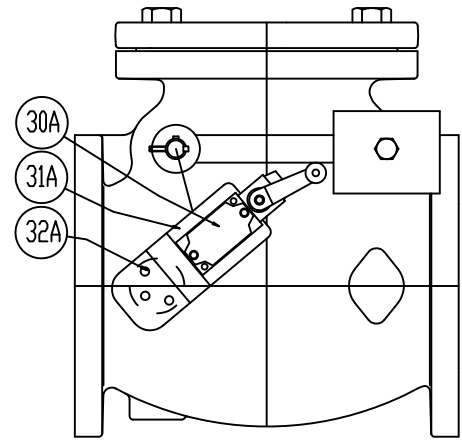

PART	QTY	DESCRIPTION	MATERIAL & ASTM SPEC.
1A	1	SIDE PLUG	BRONZE
2A	*	BOLTS	18-8 STAINLESS STEEL
3A	1	O-RING	BUNA-N
4A	1	CAP	CI A-126 CLASS B
5A	1	BODY	CI A-126 CLASS B
17A	1	EXTENDED HINGE PIN	STAINLESS STEEL A-276 (304)
18A	2	KEY FOR LEVER ARM	STAINLESS STEEL A-276 (304)
19A	1	SET SCREW	STEEL
20AB	1	LEVER ARM	STEEL
24A	1	SIDE PLUG STUFFING BOX	BRONZE
25A	*	PACKING	GRAPHITE FILLED
26A	1	GLAND	BRONZE
27A	1	WEIGHT	CI A-126 CLASS B
28A	1	SET SCREW	STEEL

AUXILIARY DUAL ARM OPTION

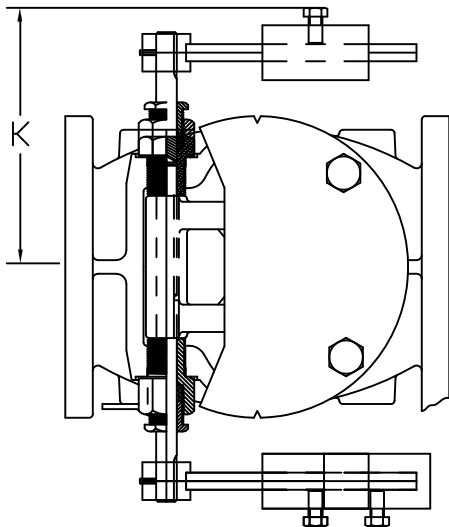

LIMIT SWITCH OPTION

30A	1	LIMIT SWITCH	PER ENGINEER SPEC
31A	1	BRACKET	STEEL
32A	*	MOUNTING SCREWS	ZINC PLATED STEEL

* VARIES ACCORDING TO SIZE

SIZE	A	B	C	D	E	F	G	H	K	WEIGHT
2	8	0.66	6	6	6	6	4.72	0.50	6.4	40
2 1/2	8.5	0.72	7	6.63	7	6	4.94	0.50	6.6	55
3	9.5	0.78	7.5	7.06	7.5	6	5.35	0.50	7.4	92
4	11.5	1.00	9	8.31	9	8.25	8.19	0.63	10.1	157
6	14	1.06	11	10.06	11	10.25	9	0.75	10.9	226
8	19.5	1.25	13.5	12.38	13.5	14.5	10.19	0.88	12.4	402
10	24.5	1.31	16	13.93	16.75	18	11.63	1.00	14.7	625
12	27.5	1.38	19	16.18	19	18	13.75	1.00	16.0	876

USE VALVE FOR VERTICAL OR HORIZONTAL FLOW

NOTE: VERTICAL FLOW MAY REQUIRE FACTORY REPOSITIONING OF LEVER ARM

NOTE: DUAL WEIGHT ARMS ONLY AVAILABLE ON 6" & HIGHER VALVES

STYLE-159-02A 2"-12" WITH RUBBER FACED CLAPPER

STYLE-159-02 2"-12" WITH BRONZE FACED CLAPPER

STYLE-159-02ALS 2"-12" WITH RUBBER FACED CLAPPER & LIMIT SWITCH

STYLE-159-02LS 2"-12" WITH BRONZE FACED CLAPPER & LIMIT SWITCH

STYLE-159-02AD 6"-12" WITH RUBBER FACED CLAPPER & DUAL ARM

STYLE-159-02D 6"-12" WITH BRONZE FACED CLAPPER & DUAL ARM

M&H VALVE COMPANY
ANNISTON, ALABAMA
A DIVISION OF MCWANE INC.

DWN: TRIJ
DATE: 9/1/12
DWG. NO.
CV-A1-LW

2" THRU 12"
LEVER & WEIGHT SWING CHECK
AWWA 508-STYLE 159-02
(PAGE 1 OF 2)

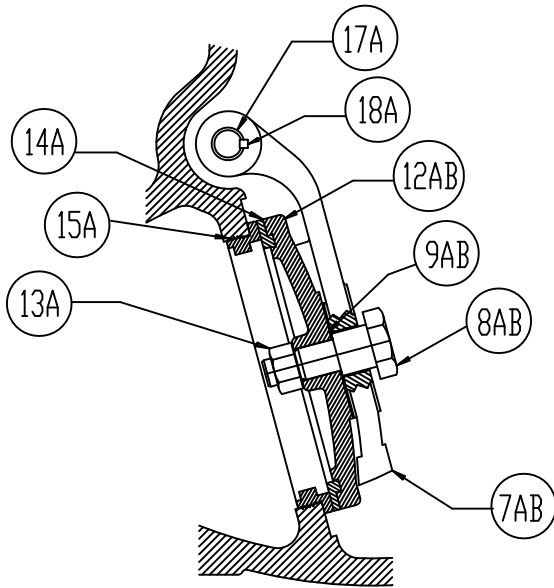

4'-12' LEVER & WEIGHT BRONZE SEATED DISC ASSEMBLY

7AB	1	HINGE W/KEYWAY	DUCTILE IRON A-536
8AB	1	DISC BOLT	(4'-8') STEEL---(10'-12') BRONZE
9AB	2	DISC BOLT WASHER (4'-8')	
12AB	1	DISC	CAST IRON A-126 CLASS B
13A	1	DISC NUT	18-8 STAINLESS STEEL
14A	1	DISC RING	BRONZE
15A	1	SEAT RING	BRONZE
17A	1	EXTENDED HINGE PIN	STAINLESS STEEL A-276 (304)
18A	2	KEY	STAINLESS STEEL A-276 (304)

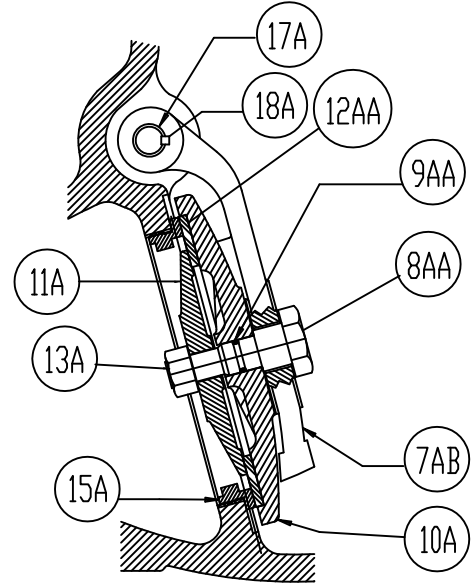

4'-12' LEVER & WEIGHT RESILIENT SEATED DISC ASSEMBLY

7AB	1	HINGE W/KEYWAY	DUCTILE IRON A-536
8AA	1	DISC BOLT	(4'-8') STEEL---(10'-12') BRONZE
9AA	1	DISC BOLT O-RING (10',12')	SYNTHETIC RUBBER
10A	1	DISC HOLDER	CAST IRON A-126 CLASS B
11A	1	DISC PLATE	BRONZE
12AA	1	DISC	SYNTHETIC RUBBER
13A	1	DISC NUT	18-8 STAINLESS STEEL
15A	1	SEAT RING	BRONZE
17A	1	EXTENDED HINGE PIN	STAINLESS STEEL A-276 (304)
18A	2	KEY	STAINLESS STEEL A-276 (304)

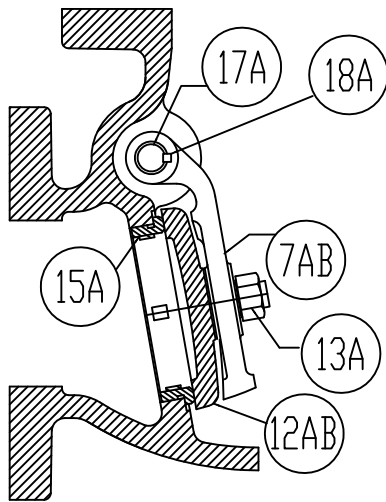

2'-3' LEVER & WEIGHT BRONZE SEATED DISC ASSEMBLY

7AB	1	HINGE W/KEYWAY	BRONZE
12AB	1	DISC (WITH INTEGRAL DISC BOLT)	BRONZE
13A	1	DISC NUT	18-8 STAINLESS STEEL
15A	1	SEAT RING	BRONZE
17A	1	EXTENDED HINGE PIN	STAINLESS STEEL A-276 (304)
18A	2	KEY	STAINLESS STEEL A-276 (304)

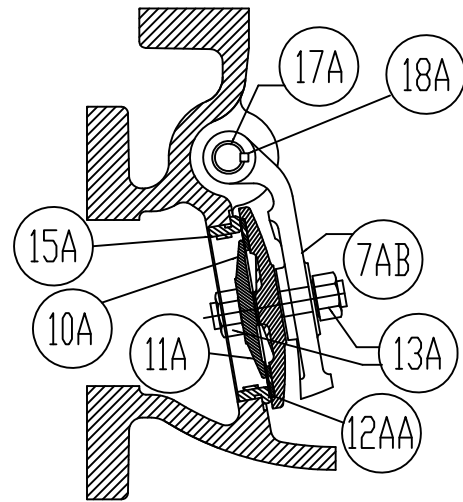

2'-3' LEVER & WEIGHT RESILIENT SEATED DISC ASSEMBLY

7AB	1	HINGE W/KEYWAY	BRONZE
10A	1	DISC HOLDER (WITH INTEGRAL DISC BOLT)	BRONZE
11A	1	DISC PLATE	BRONZE
12AA	1	DISC	SYNTHETIC RUBBER
13A	2	DISC NUT	18-8 STAINLESS STEEL
15A	1	SEAT RING	BRONZE
17A	1	EXTENDED HINGE PIN	STAINLESS STEEL A-276 (304)
18A	2	KEY	STAINLESS STEEL A-276 (304)

M&H VALVE COMPANY
ANNISTON, ALABAMA
A DIVISION OF MCWANE INC.

DWN: TRIJ
DATE: 9/1/12
DWG. NO.
CV-A2-LW

2" THRU 12"
LEVER & WEIGHT SWING CHECK
AWWA C508-STYLE 159-02
(PAGE 2 OF 2)

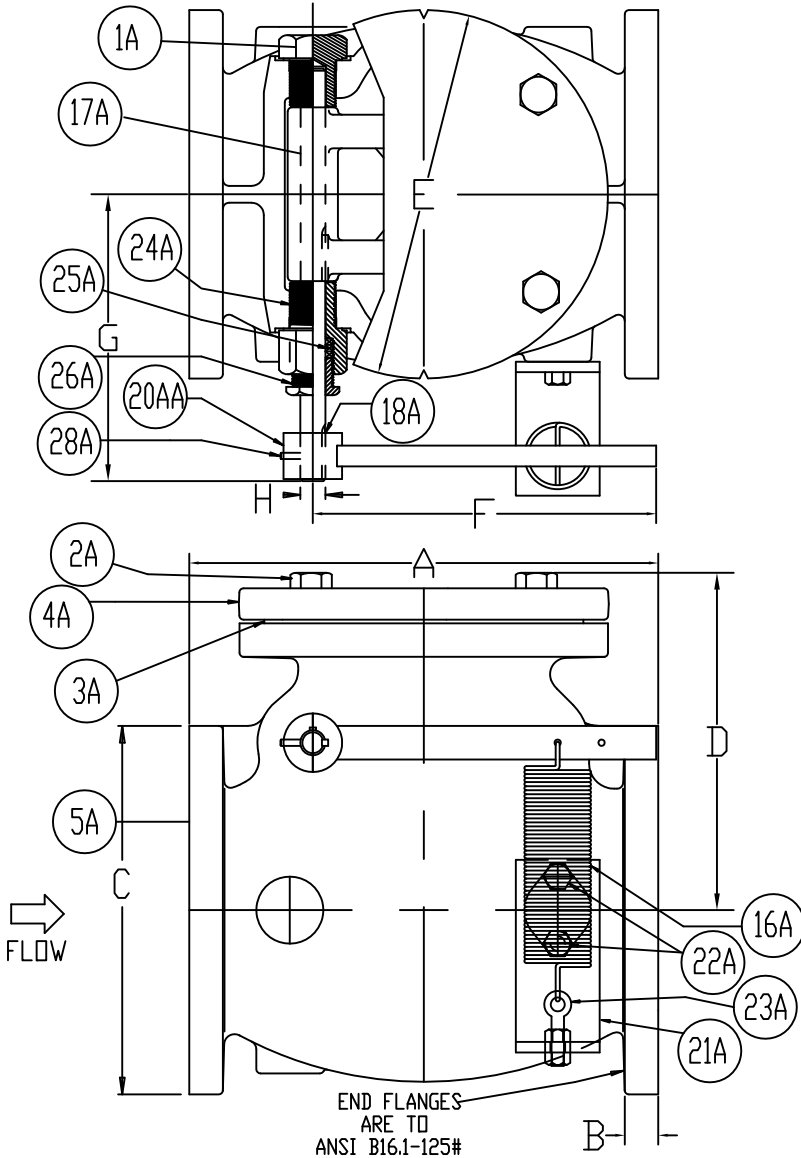

SIZE	A	B	C	D	E	F	G	H	WEIGHT
2	8	0.66	6	6	6	6	4.72	0.50	40
2 1/2	8.5	0.72	7	6.63	7	6	4.94	0.50	54
3	9.5	0.78	7.5	7.06	7.5	6	5.35	0.50	92
4	11.5	1.00	9	8.31	9	8.25	8.19	0.63	157
6	14	1.06	11	10.06	11	10.25	9	0.75	226
8	19.5	1.25	13.5	12.38	13.5	14.50	10.19	0.88	402
10	24.5	1.31	16	13.93	16.75	18	11.63	1.00	625
12	27.5	1.38	19	16.18	19	18	13.75	1.00	876

USE VALVE FOR VERTICAL OR HORIZONTAL FLOW
 NOTE: VERTICAL FLOW MAY REQUIRE FACTORY REPOSITIONING OF LEVER ARM
 STYLE-259-02A 2"-12" WITH RUBBER FACED CLAPPER
 STYLE-259-02 2"-12" WITH BRONZE FACED CLAPPER
 STYLE-259-02ALS 2"-12" WITH RUBBER FACED CLAPPER & LIMIT SWITCH
 STYLE-259-02LS 2"-12" WITH BRONZE FACED CLAPPER & LIMIT SWITCH

LIMIT SWITCH OPTION

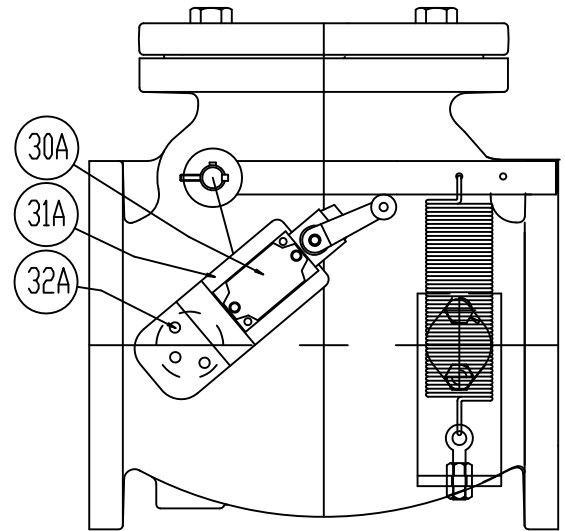

PART	QTY	DESCRIPTION	MATERIAL & ASTM SPEC.
1A	1	SIDE PLUG	BRONZE
2A	*	BOLTS	18-8 STAINLESS STEEL
3A	1	O-RING	BUNA-N
4A	1	CAP	CI A-126 CLASS B
5A	1	BODY	CI A-126 CLASS B
16A	1	SPRING	STEEL
17A	1	EXTENDED HINGE PIN	STAINLESS STEEL A-276 (304)
18A	2	KEY FOR LEVER ARM	STAINLESS STEEL A-276 (304)
20AA	1	LEVER ARM	STEEL
21A	1	BRACKET	STEEL
22A	2	HEX HEAD BRACKET BOLTS	STEEL
23A	1	EYE BOLT W/ 2 HEX NUTS	STEEL
24A	1	SIDE PLUG STUFFING BOX	BRONZE
25A	*	PACKING	GRAPHITE FILLED
26A	1	GLAND	BRONZE
28A	1	SET SCREW	STEEL

LIMIT SWITCH OPTION

PART	QTY	DESCRIPTION	MATERIAL & ASTM SPEC.
30A	1	LIMIT SWITCH	PER ENGINEER SPEC
31A	1	BRACKET	STEEL
32A	*	MOUNTING SCREWS	ZINC PLATED STEEL

* VARIES ACCORDING TO SIZE

M&H VALVE COMPANY
 ANNISTON, ALABAMA
 A DIVISION OF MCWANE INC.

DWN: TRIJ
 DATE: 9/1/12
 DWG. NO.
 CV-A1-LS

2" THRU 12"
 LEVER & SPRING SWING CHECK
 AWWA C508-STYLE 259-02
 (PAGE 1 OF 2)

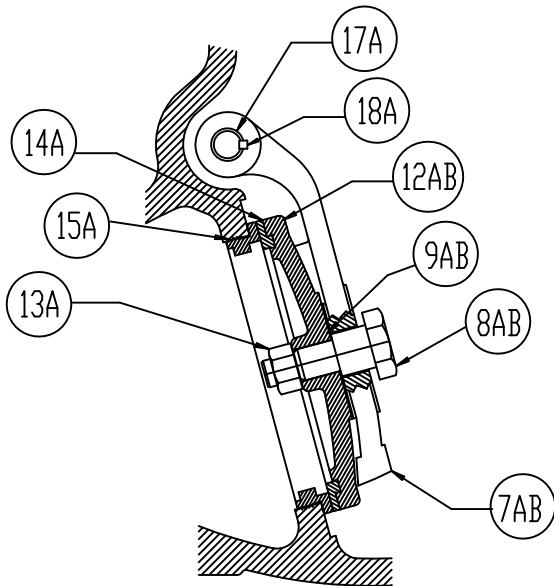

4'-12" LEVER & WEIGHT BRONZE SEATED DISC ASSEMBLY

7AB	1	HINGE W/KEYWAY	DUCTILE IRON A-536
8AB	1	DISC BOLT	(4'-8") STEEL---(10'-12") BRONZE
9AB	2	DISC BOLT WASHER (4'-8")	
12AB	1	DISC	CAST IRON A-126 CLASS B
13A	1	DISC NUT	18-8 STAINLESS STEEL
14A	1	DISC RING	BRONZE
15A	1	SEAT RING	BRONZE
17A	1	EXTENDED HINGE PIN	STAINLESS STEEL A-276 (304)
18A	2	KEY	STAINLESS STEEL A-276 (304)

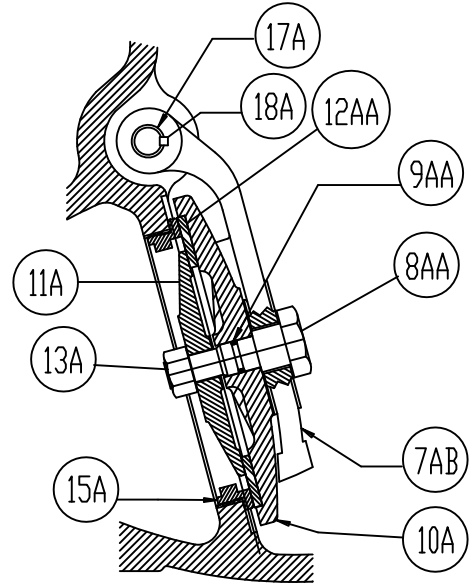

4'-12" LEVER & WEIGHT RESILIENT SEATED DISC ASSEMBLY

7AB	1	HINGE W/KEYWAY	DUCTILE IRON A-536
8AA	1	DISC BOLT	(4'-8") STEEL---(10'-12") BRONZE
9AA	1	DISC BOLT O-RING (10',12")	SYNTHETIC RUBBER
10A	1	DISC HOLDER	CAST IRON A-126 CLASS B
11A	1	DISC PLATE	BRONZE
12AA	1	DISC	SYNTHETIC RUBBER
13A	1	DISC NUT	18-8 STAINLESS STEEL
15A	1	SEAT RING	BRONZE
17A	1	EXTENDED HINGE PIN	STAINLESS STEEL A-276 (304)
18A	2	KEY	STAINLESS STEEL A-276 (304)

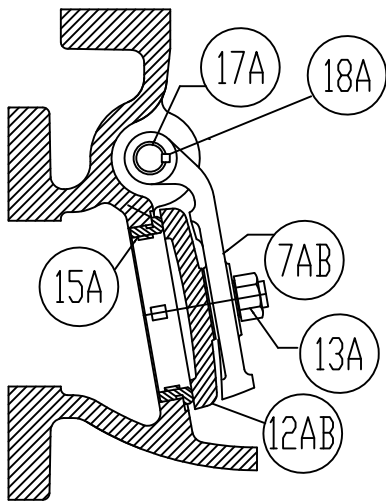

2'-3" LEVER & WEIGHT BRONZE SEATED DISC ASSEMBLY

7AB	1	HINGE W/KEYWAY	BRONZE
12AB	1	DISC (WITH INTEGRAL DISC BOLT)	BRONZE
13A	1	DISC NUT	18-8 STAINLESS STEEL
15A	1	SEAT RING	BRONZE
17A	1	EXTENDED HINGE PIN	STAINLESS STEEL A-276 (304)
18A	2	KEY	STAINLESS STEEL A-276 (304)

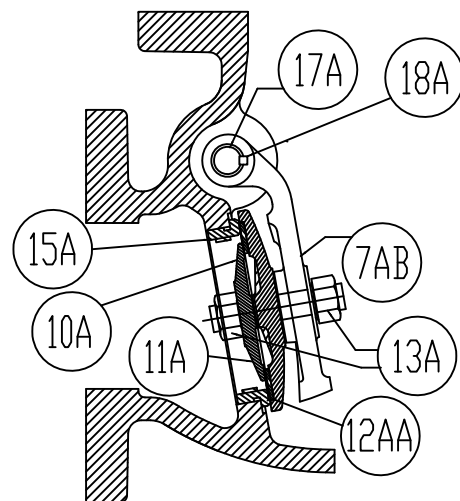

2'-3" LEVER & WEIGHT RESILIENT SEATED DISC ASSEMBLY

7AB	1	HINGE W/KEYWAY	BRONZE
10A	1	DISC HOLDER (WITH INTEGRAL DISC BOLT)	BRONZE
11A	1	DISC PLATE	BRONZE
12AA	1	DISC	SYNTHETIC RUBBER
13A	2	DISC NUT	18-8 STAINLESS STEEL
15A	1	SEAT RING	BRONZE
17A	1	EXTENDED HINGE PIN	STAINLESS STEEL A-276 (304)
18A	2	KEY	STAINLESS STEEL A-276 (304)

M&H VALVE COMPANY
ANNISTON, ALABAMA
A DIVISION OF MCWANE INC.

DWN: TRIJ
DATE: 9/1/12
DWG. NO.
CV-A2-LS

2" THRU 12"
LEVER & SPRING SWING CHECK
AWWA C508-STYLE 259-02
(PAGE 2 OF 2)

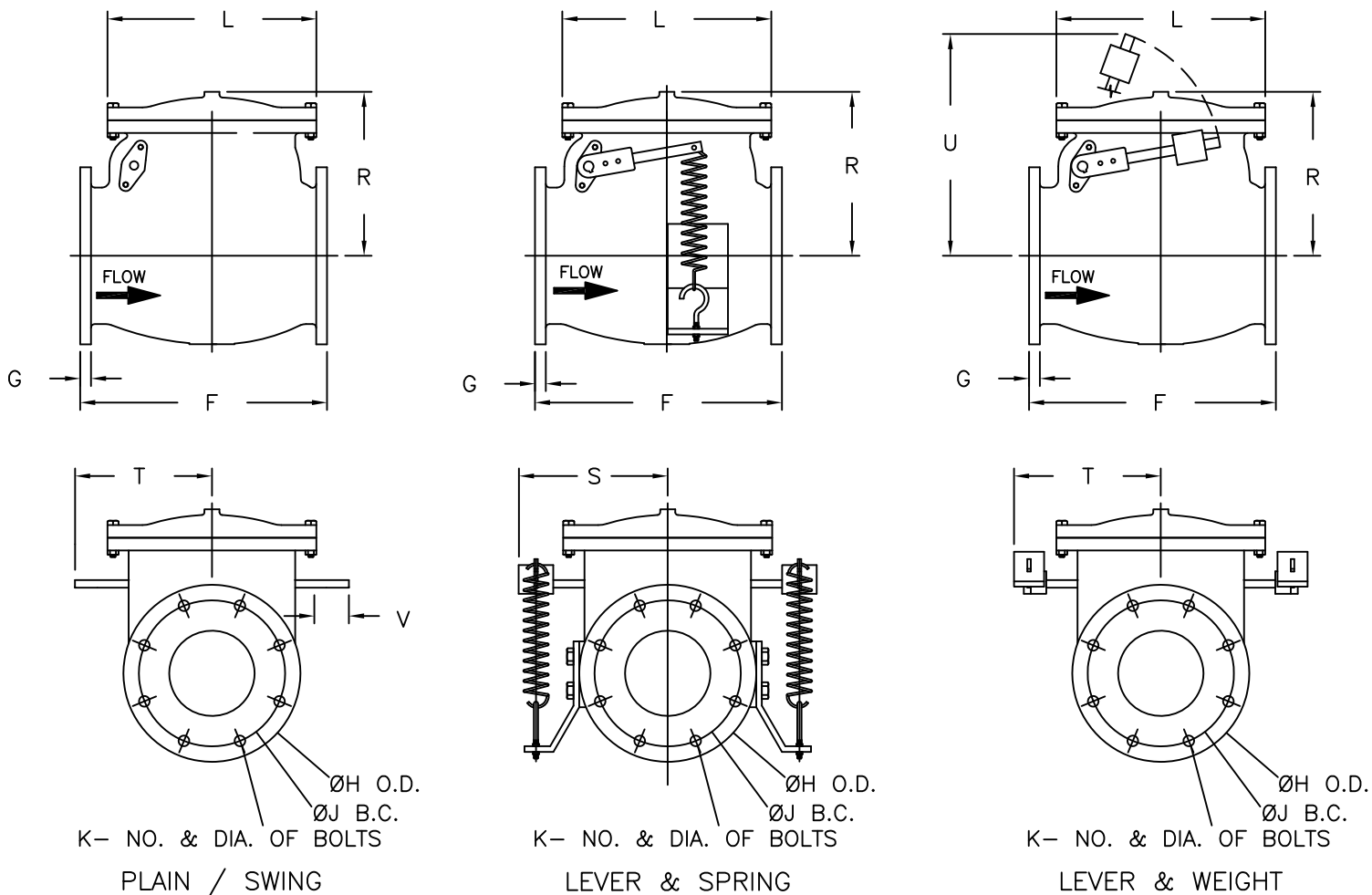

VALVE SIZE	14	16	18	20	24	30
F	30	35	36 1/2	37 5/8	44	49 1/2
G	1 3/8	1 7/16	1 9/16	1 11/16	1 7/8	2 1/8
H	21	23 1/2	25	27 1/2	32	38 3/4
J	18 3/4	21 1/4	22 3/4	25	29 1/2	36
K	12-1	16-1	16-1 1/8	20-1 1/8	20-1 1/4	28-1 1/4
L	23 1/2	27 1/2	27 1/2	32	38 3/4	43 3/4
R	18 3/4	23	25	24 1/2	28	32 7/8

LEVER & SPRING CHECK VALVES--STYLE 259-02

S	18 1/2	19	20 3/4	22 1/2	26	28 1/4
WEIGHT	1150	1630	1835	2500	3415	4950

LEVER & WEIGHT CHECK VALVES--STYLE 159-02

T	18 1/2	19	20 3/4	22 1/2	26	28 1/4
U	32 1/2	34 1/2	40	42	54 1/2	57 1/2
WEIGHT	1130	1530	1903	2383	3298	5550

PLAIN / SWING CHECK VALVES--STYLE 59-02

T	18 1/2	19	20 3/4	22 1/2	26	28 1/4
WEIGHT	1060	1460	1750	2230	3040	5200

DIM 'V' CONSULT M&H FOR MAX. CUT-OFF OF HINGE PIN TO ELIM. CLEARANCE PROBLEMS

M&H VALVE COMPANY
ANNISTON, ALABAMA
A DIVISION OF MCWANE INC.

DWN: TRIJ
DATE: 1/1/11
DWG. NO.
LCV-A1

14" THRU 30" CHECK VALVES
FLANGED ENDS
ALL STYLES
DIMENSIONS

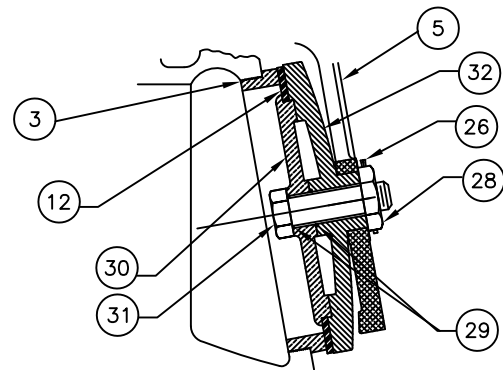
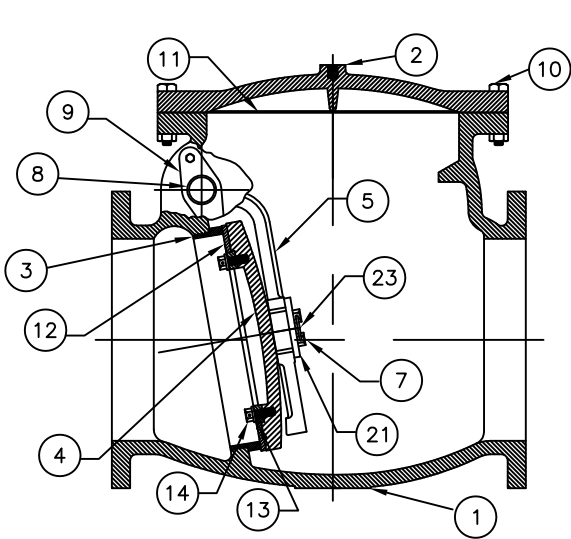

14" CLAPPER ASSEMBLY

5	1	CLAPPER ARM	DUCTILE IRON ASTM -536
12	1	CLAPPER RING	NEOPRENE
26	1	COTTER PIN	SS 304
28	1	CLAPPER NUT	BRONZE CDA 86400
29	2	GASKET	COPPER NON-ASBESTOS
30	1	CLAMPING RING	BRONZE CDA 84400
31	1	CAP SCREW OR BOLT	SS 18-8
32	1	CLAPPER	CI A-126 CLASS B

14"-30" CHECK VALVE BODY

PART NO	QTY	DESCRIPTION	MATERIAL & ASTM SPEC
1	1	BODY	CI A-126 CLASS B
2	1	COVER	CI A-126 CLASS B
3	1	BODY RING	BRONZE CDA 84400
8	1	HINGE PIN	STN. STL A-276-303
9	2	GLAND	CI A-126 CLASS B
10	*	COVER BOLTS & NUTS	STEEL A-307 GRADE B
11	1	COVER GASKET	NON-ASBESTOS

16" - 30" CLAPPER ASSEMBLY

4	1	CLAPPER	CI A-126 CLASS B
5	1	CLAPPER ARM	DUCTILE IRON ASTM -536
7	*	CAP SCREW	BRONZE B-21
12	1	CLAPPER RING	NEOPRENE
13	1	RING CLAMP	BRONZE CDA 84400
14	*	RING CLAMP CAP SCREW	BRONZE B-21
21	1	CAP PLATE	COPPER ALLOY 864/ASTM-132
23	1	LOCK WIRE	STAINLESS STEEL

* VARIES

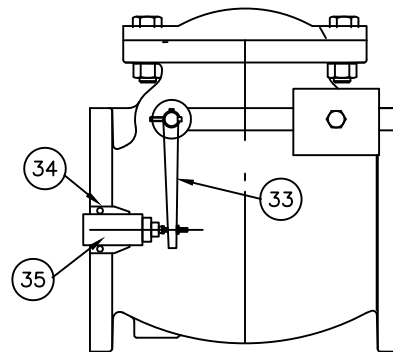

LIMIT SWITCH OPTION

33	1	TRIPPER ARM	STEEL
34	1	MOUNTING BRACKET	STEEL
35	1	LIMIT SWITCH	SD-D-TYPE-CR53E

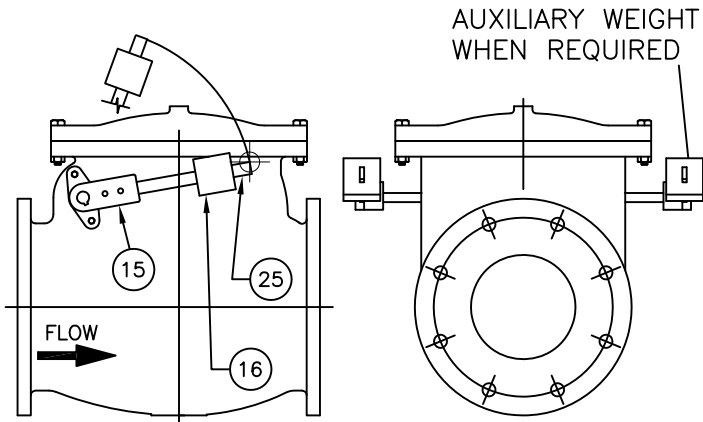

LEVER & WEIGHT CHECK VALVE

15	1	WEIGHT LEVER ARM	CI A-126 CLASS B
16	1	WEIGHT	FAB. STEEL
25	1	WEIGHT ARM BAR	CR STEEL C-1018/1020

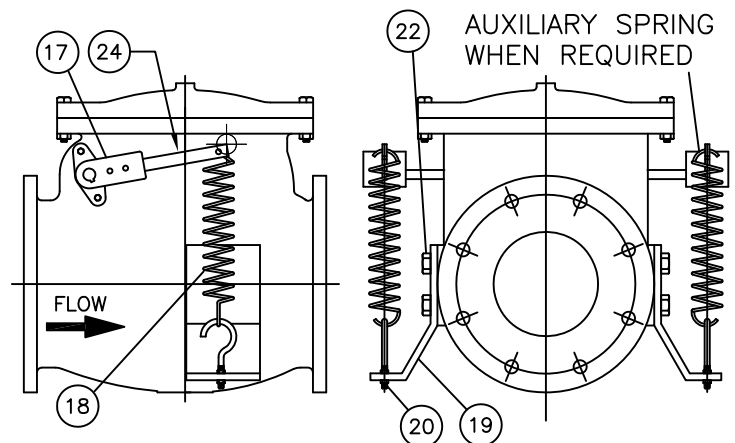

LEVER & SPRING CHECK VALVE

17	1	SPRING ARM LEVER	CI A-126 CLASS B
18	1	SPRING	STEEL
19	1	SPRING BRACKET	STEEL
20	1	SPRING EYEBOLT	STEEL A-307 GRADE B
22	*	SPRING BRACKET CAP SCREW	STEEL A-307 GRADE B
24	1	SPRING ARM BAR	CR STEEL C-1018/1020

* VARIES

M&H VALVE COMPANY
ANNISTON, ALABAMA
A DIVISION OF MCWANE INC.

DWN: TRIJ
DATE: 1/1/11
DWG. NO.
LCV-A2

14" THRU 30" CHECK VALVES
FLANGED ENDS
ALL STYLES
MATERIAL LIST

Note Regarding 14"-36" Check Valves:

Currently, M&H Valve supplies the standard-wall check valves as our standard on 14"-30" Valves. However, in 2013, we will begin transitioning to the reduced-wall ductile iron check valves. This move will change the lay lengths of these valves in most cases. The 36" Check Valve is only available as a reduced-wall ductile iron valve. Please contact our sales staff for further information on this transition.

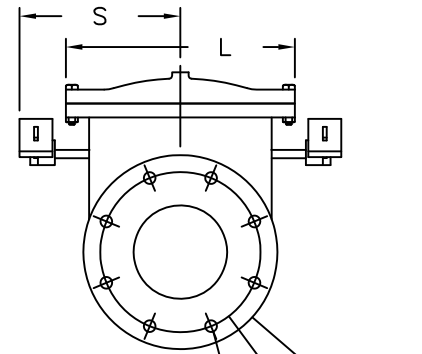
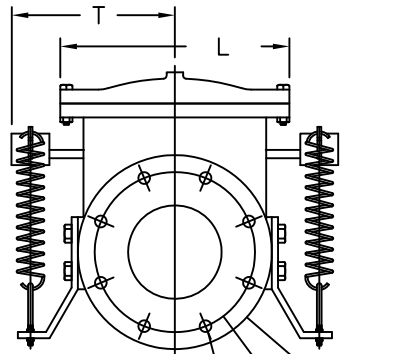
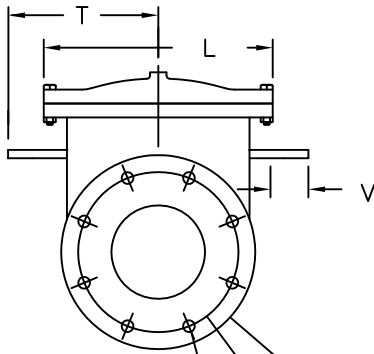
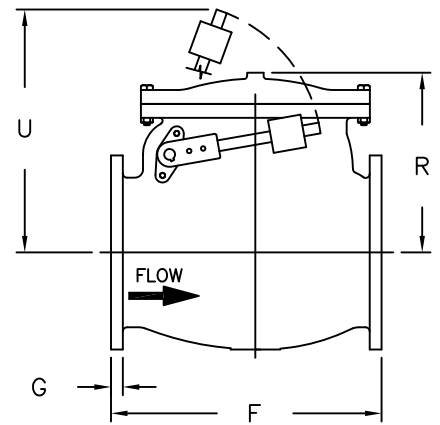
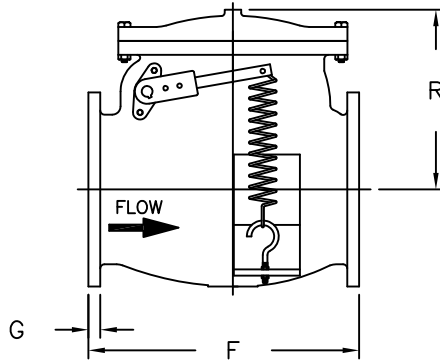
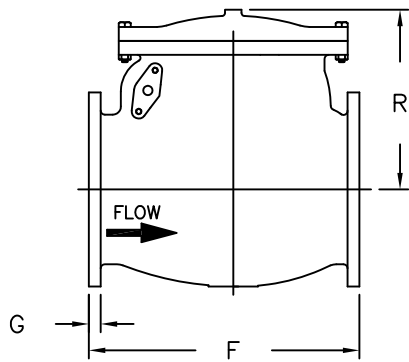

ØH O.D.
ØJ B.C.
K- NO. & DIA. OF BOLTS

ØH O.D.
ØJ B.C.
K- NO. & DIA. OF BOLTS

ØH O.D.
ØJ B.C.
K- NO. & DIA. OF BOLTS

PLAIN / SWING

LEVER & SPRING

LEVER & WEIGHT

DIM 'V' CONSULT M&H FOR MAX. CUT-OFF OF HINGE PIN TO ELIM. CLEARANCE PROBLEMS

VALVE SIZE	14	16	18	20	24	30	36
F	31	36	40	40	48	49 1/2	63
G	1 3/8	1 7/16	1 9/16	1 11/16	1 7/8	2 1/8	2 3/8
H	21	23 1/2	25	27 1/2	32	38 3/4	46
J	18 3/4	21 1/4	22 3/4	25	29 1/2	36	42 3/4
K	12-1	16-1	16-1 1/8	20-1 1/8	20-1 1/4	28-1 1/4	32-1 1/2
L	22 3/8	25 3/4	27 1/2	32	34 7/8	41	47
R	18 3/4	19 1/16	25	24 1/2	24 11/16	28	34

LEVER & SPRING CHECK VALVES--STYLE 259-02

T	18 1/2	19	20 3/4	22 1/2	26	28 1/4	35
WEIGHT	1150	1630	1835	2500	3415	4950	

LEVER & WEIGHT CHECK VALVES--STYLE 159-02

S	19	19 1/2	20 3/4	22 1/2	27 3/8	29 5/8	35
U	32 1/2	34 1/2	40	42	54 1/2	57 1/2	
WEIGHT	1130	1530	1903	2383	3298	5550	

PLAIN / SWING CHECK VALVES--STYLE 59-02

T	18 1/2	19	20 3/4	22 1/2	26	28 1/4	35
WEIGHT	1060	1460	1750	2230	3040	5200	

NOTE:

THESE DIMENSIONS WILL BE PHASED IN DURING 2013. CONTACT FACTORY FOR EXACT LAYING LENGTHS. CHECK LAYING LENGTHS WHEN REPLACING VALVES MANUFACTURED PRIOR TO 2013.

M&H VALVE COMPANY
ANNISTON, ALABAMA
A DIVISION OF MCWANE INC.

DWN: TRIJ
DATE: 10/22/12
DWG. NO.
LCV-A2

14" THRU 36" CHECK VALVES
FLANGED ENDS
ALL STYLES
DIMENSIONS