

REVISIONS				
ECN	REV.	DESCRIPTION	BY	DATE
	1	RELEASED	J CAPPER	3/28/2017
	2	EDITED DRAWING NOTES, HW COLOR	J CAPPER	8/16/2017
	3	CORRECTED MODEL COLOR	J CAPPER	9/20/2017
	4	CORRECTED MODEL COLOR	J CAPPER	9/25/2017
	5	CORRECTED COVER SEAT LETTERING	J CAPPER	9/27/2017
	6	MADE FASTENERS 316 SS STANDARD, CORRECTED 14" VALVE HW, EDITED MARKINGS NOTE	DPB, J CAPPER	2/19/2019
	7	ADDED GEAR RATIO & # OF TURNS TO TABLE, UPDATED WITH CORRECT BODY MARKINGS	CAW	3/22/2019

SIZE RANGE	WATER WORKING PRESSURE PSI	HYDROSTATIC TEST PSI
3-12	175 PSI	350 PSI
14-16	150 PSI	300 PSI

ITEM#	PART NAME	ASTM/ DESIGNATION	QTY.
1	LOWER SLEEVE BEARING	SINTERED ALLOY SS316	11
2	LOWER GRIT SEAL	NBR	1
3	LOWER THRUST WASHER	PTFE	1
4	PLUG	ASTM A536 65-45-12 OR 70-50-05 +NBR	1
5	BODY	ASTM A536 65-45-12 OR 70-50-05	1
6	UPPER THRUST WASHER	PTFE	1
7	UPPER GRIT SEAL	NBR	1
8	UPPER SLEEVE BEARING	SINTERED ALLOY SS316	1
9	V-PACKING	NBR	1
10	FOLLOWER GLAND	ASTM A536 65-45-12 OR 70-50-05	1
11	HEX NUTS	STAINLESS STEEL ASTM A276.T316	2
12	STUDS	STAINLESS STEEL ASTM A276.T316	2
13	ADAPTER	ASTM A536 65-45-12 OR 70-50-05	1
14	ADAPTER BOLTS	STAINLESS STEEL ASTM A276.T316	6
15	COVER BOLTS	STAINLESS STEEL ASTM A276.T316	4
16	COVER	ASTM A536 65-45-12 OR 70-50-05	1
17	COVER O-RING	NBR	1
18	JPM GEAR w/ HW	-----	1
19	SLOT TYPE SPRING PIN	ASTM A29 1566	1

NOTE:
 FOR SERVICES WITH 3"- 8" PLUG VALVES IN EXCESS OF 25 PSI, USE OF A GEAR IS RECOMMENDED.
 GEAR MODEL AND BRAND ARE SUBJECT TO CHANGE WITHOUT NOTICE.

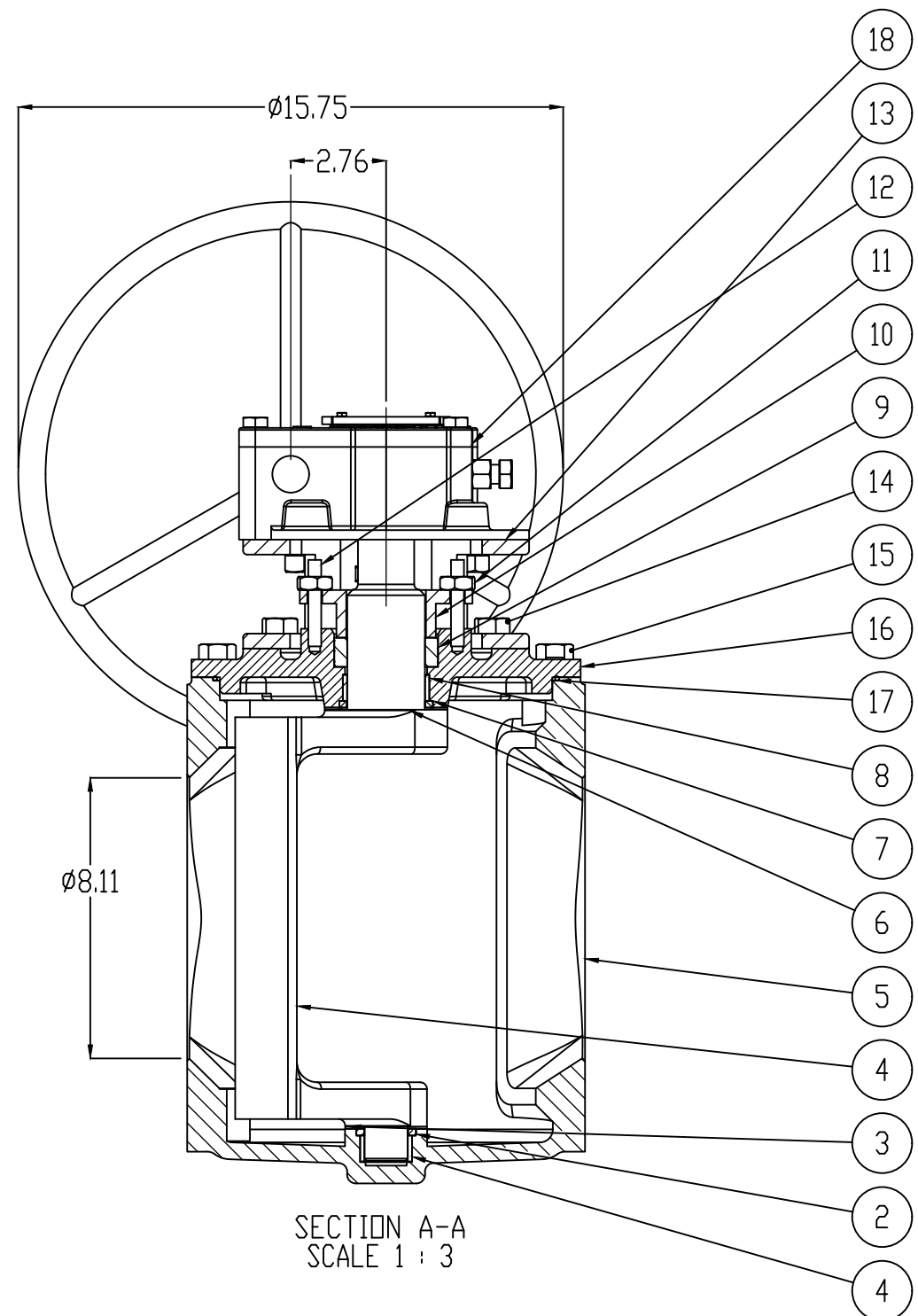
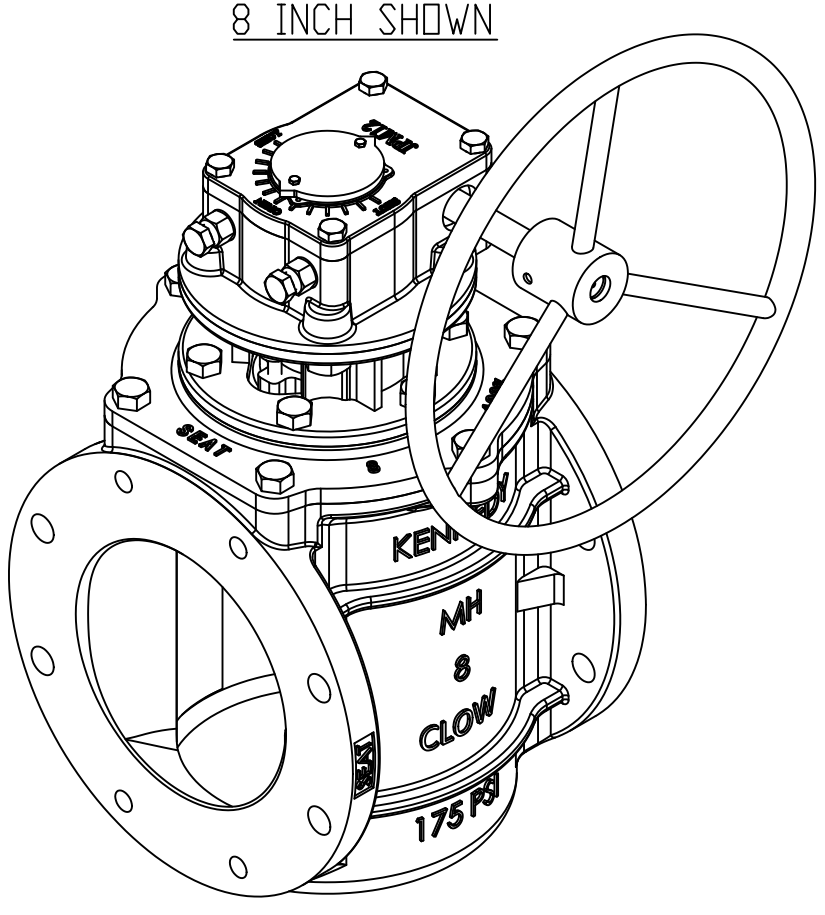
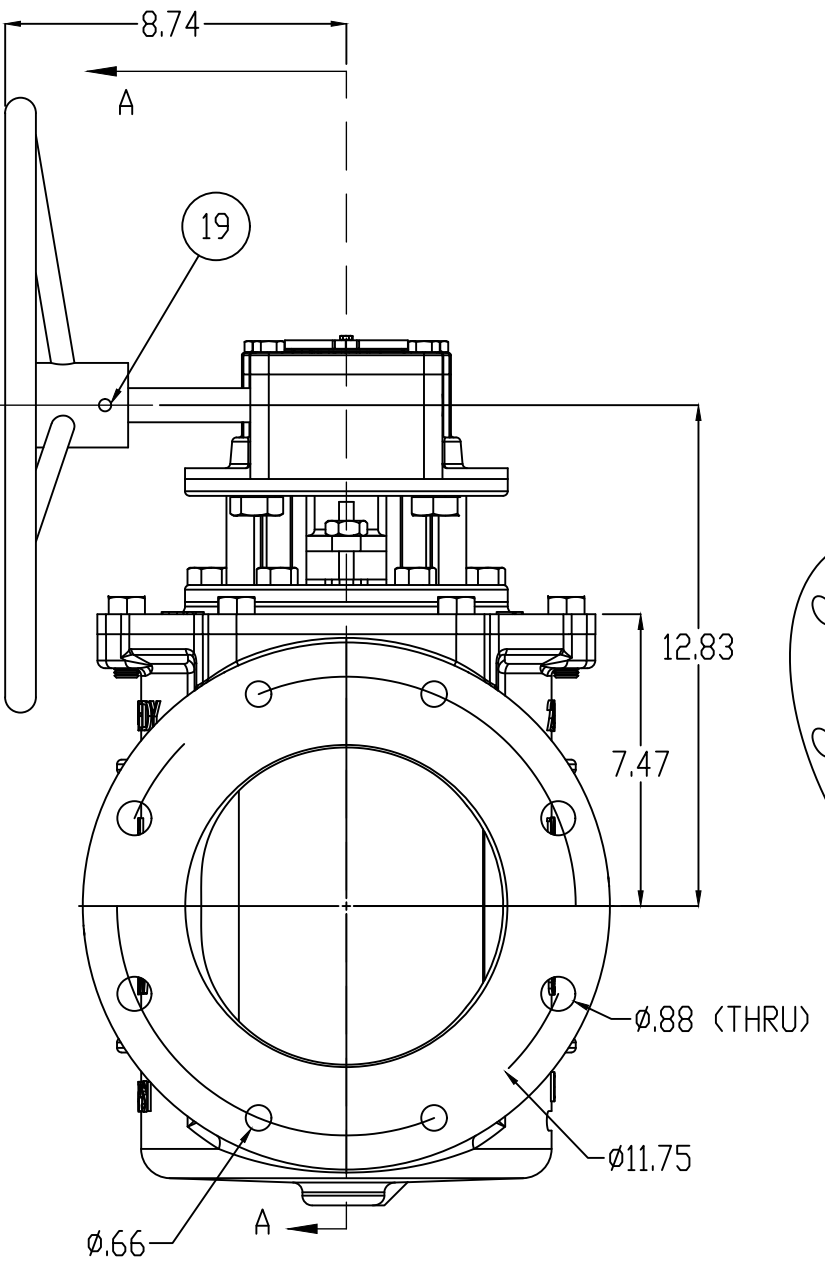
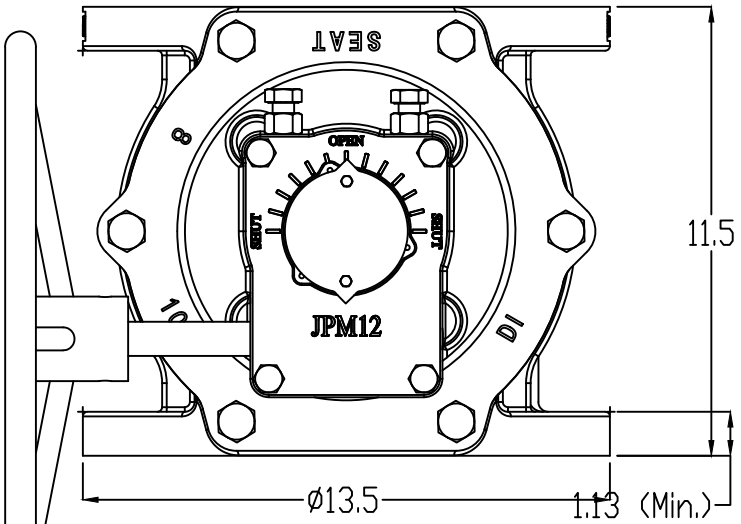

NOTE:
 1. BODY CASTINGS ARE TRI-MARKED WITH "CLOW," "KENNEDY," AND "M&H"

A [VALVE SIZE]	B	C	D	E	F	G	H	I	J	K	WEIGHT (LBS.)	JPM GEAR	GEAR RATIO	# OF TURNS TO OPEN (APPROX.)	Ø HW (in)
3	8.00	.75	7.50	4 x 5/8-11 ∇ .79	-	6.00	3.76	7.50	8.8	2.8	75 LBS	JPM12A	40	10	8
4	9.00	.94	9.00	4 x 5/8-11 ∇ .79	4 x .75	7.50	4.65	8.28	8.8	2.8	100 LBS	JPM12A	40	10	8
6	10.50	1.02	11.00	4 x 3/4-10 ∇ .79	4 x .81	9.50	5.78	10.30	8.8	2.8	165 LBS	JPM12FA	40	10	12
8	11.50	1.13	13.50	4 x 3/4-10 ∇ .79	4 x .88	11.75	7.48	12.54	8.8	2.8	230 LBS	JPM12FA	40	10	16
10	13.00	1.19	16.00	8 x 7/8-9 ∇ .79	4 x 1.00	14.25	8.88	14.02	11.3	3.9	340 LBS	JPM14A	53	13	20
12	14.00	1.26	19.00	8 x 7/8-9 ∇ .79	4 x 1.00	17.00	11.00	16.38	12.1	3.9	480 LBS	JPM14A	53	13	24
14	17.00	1.38	21.00	8 x 1-8 UNS ∇ 1.54	4 x 1.13	18.75	12.88	18.00	14.9	4.9	720 LBS	JPM15A	68	17	30
16	17.17	1.44	23.50	8 x 1-8 UNS ∇ 1.06	8 x 1.13	21.25	14.69	22.50	14.9	4.9	850 LBS	JPM15A	68	17	30

DRAWN	J CAPPER	3/28/2017		M&H VALVE	
CHECKED	DB	3/29/2017		Division of McWane, Inc.	
APPROVED				605 West 23rd Street, Anniston, Alabama 36201	
DO NOT SCALE DRAWING			TITLE:		
MATERIAL: SEE TABLE			3"-16" FULL FLOW FLG EPV		
Weight: SEE TABLE			6412-FF w/ JPM GEAR - HW		
SIZE	D	DWG. NO.	SUB910399T		REV
					7
<small>PROPRIETARY AND CONFIDENTIAL THE INFORMATION CONTAINED IN THIS DRAWING IS THE PROPERTY OF M&H VALVE CO. ANY REPRODUCTION IN PART OR AS A WHOLE WITHOUT THE WRITTEN PERMISSION OF M&H VALVE CO. IS PROHIBITED.</small>					

REVISIONS			
REV.	DESCRIPTION	BY	DATE
1	RELEASED	J CAPPER	3/28/2017
2	EDITED DRAWING NOTES	J CAPPER	8/16/2017
3	CHANGED MODEL COLOR	J CAPPER	9/20/2017
4	CHANGED MODEL COLOR	J CAPPER	9/25/2017
5	CORRECTED COVER "SEAT" LETTERING	J CAPPER	9/27/2017
6	ADDED BURIED GEAR NOTE	J CAPPER	10/5/2017
7	REMOVED ADAPTER WINDOWS	J CAPPER	8/1/2018
8	UPDATED J DIM, MADE FASTENERS 316 SS STANDARD, EDITED MARKINGS NOTE	J CAPPER	2/22/2019
9	ADDED GEAR RATIO & # OF TURNS TO OPEN COLUMNS, UPDATED WITH CORRECT BODY MARKINGS	CAW	3/25/2019

VALVE SIZE RANGE	WATER WORKING PRESSURE (PSI)	HYDROSTATIC TEST (PSI)
3-12"	175	350
14-16"	150	300

ITEM#	PART NAME	ASTM/ DESIGNATION	QTY.
1	LOWER SLEEVE BEARING	SINTERED ALLOY SS316	11
2	LOWER GRIT SEAL	NBR	1
3	LOWER THRUST WASHER	PTFE	1
4	PLUG	ASTM A536 GR.65-45-12 or GR.75-50-05 +NBR	1
5	BODY	ASTM A536 GR. 65-45-12 or 70-50-05	1
6	UPPER THRUST WASHER	PTFE	1
7	UPPER GRIT SEAL	NBR	1
8	UPPER SLEEVE BEARING	SINTERED ALLOY SS316	1
9	V-PACKING	NBR	1
10	FOLLOWER GLAND	ASTM A536 GR. 65-45-12 or 70-50-05	1
11	HEX NUTS	STAINLESS STEEL ASTM A276.T316	2
12	STUDS	STAINLESS STEEL ASTM A276.T316	2
13	ADAPTER	ASTM A536 GR. 65-45-12 or 70-50-05	1
14	ADAPTER BOLTS	STAINLESS STEEL ASTM A276.T316	6
15	COVER BOLTS	STAINLESS STEEL ASTM A276.T316	4
16	COVER	ASTM A536 GR. 65-45-12 or 70-50-05	1
17	COVER O-RING	NBR	1
18	JPM GEAR w/ DP NUT	-----	1
19	SLOT TYPE SPRING PIN	ASTM A29 1566	1

NOTE:
 FOR SERVICES WITH 3"- 8" PLUG VALVES IN EXCESS OF 25 PSI, USE OF A GEAR IS RECOMMENDED.
 GEAR MODEL AND BRAND ARE SUBJECT TO CHANGE WITHOUT NOTICE.

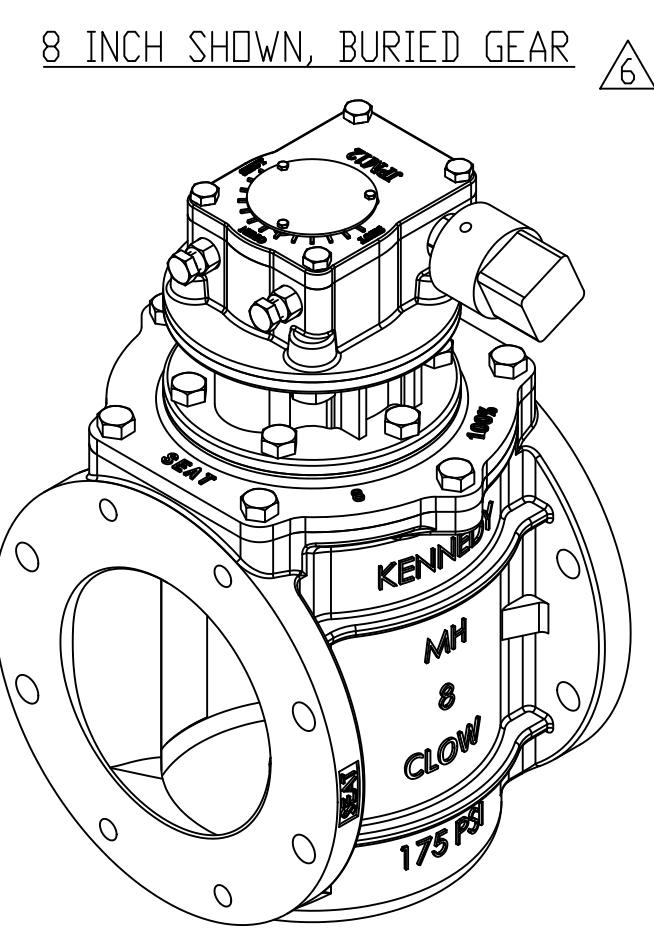
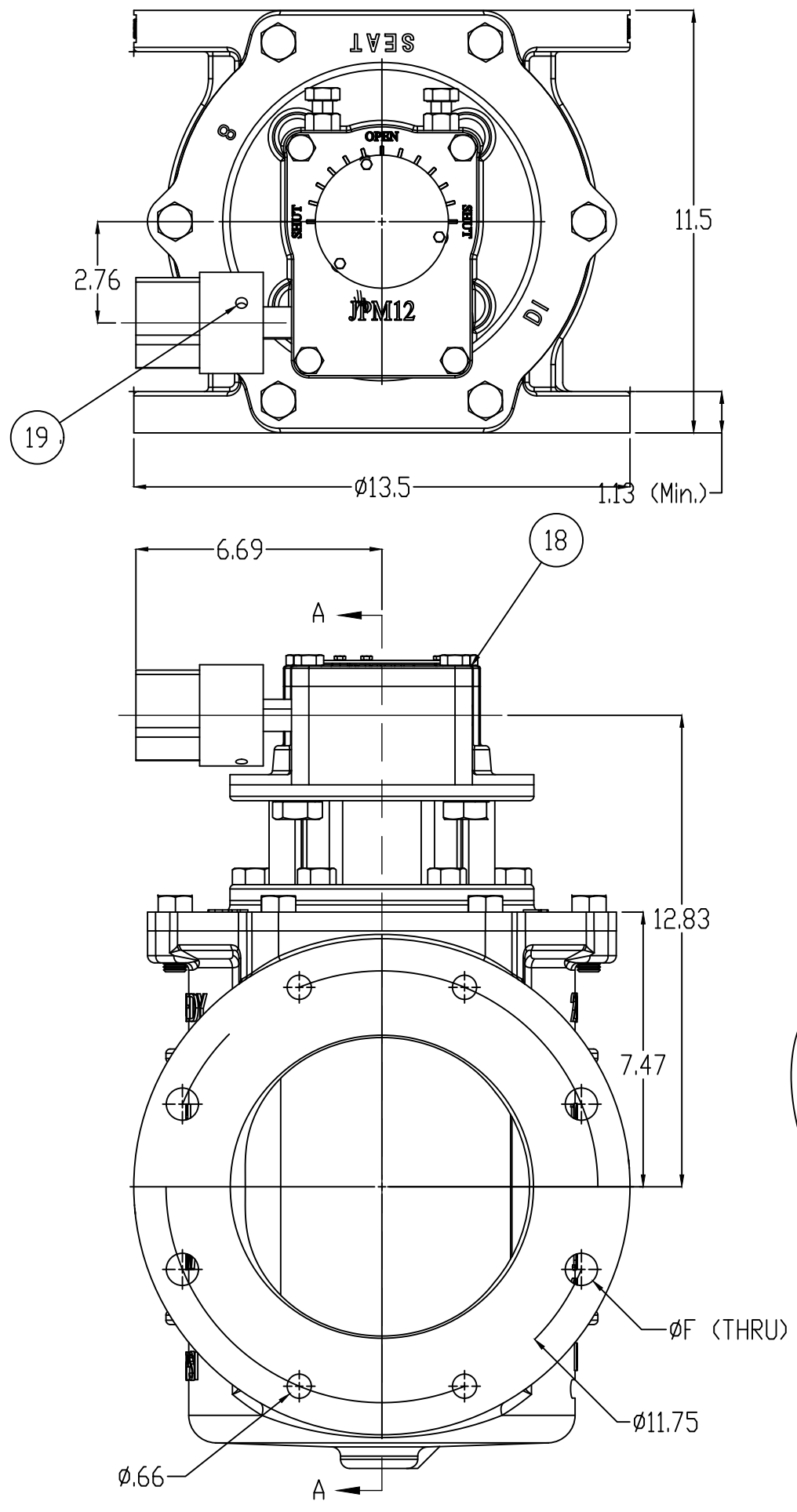

NOTE:
 1. BODY CASTINGS ARE TRI-MARKED WITH "CLOW," "KENNEDY," AND "M&H"

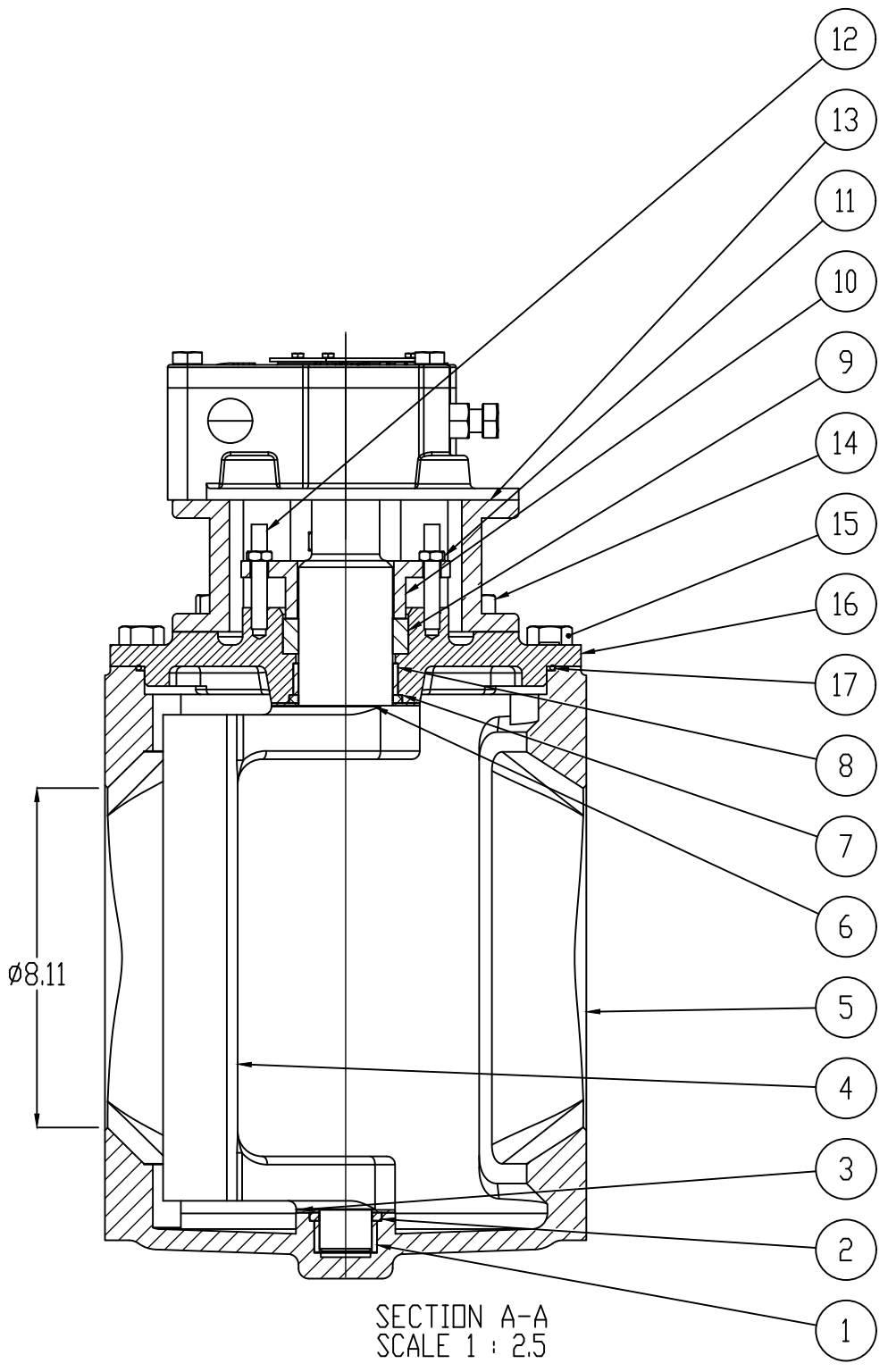

SECTION A-A
 SCALE 1 : 2.5

A [VALVE SIZE]	B	C	D	E	F	G	H	I	J	K	WEIGHT [LBS.]	JPM GEAR	GEAR RATIO	# OF TURNS TO OPEN (APPROX.)
3	8.00	.75	7.50	4 x 5/8-11 ∇ .79	-	6.00	3.76	7.50	9.01	2.8	75 LBS	JPM12B	40	10
4	9.00	.94	9.00	4 x 5/8-11 ∇ .79	4 x .75	7.50	4.65	8.28	9.01	2.8	100 LBS	JPM12B	40	10
6	10.50	1.02	11.00	4 x 3/4-10 ∇ .79	4 x .81	9.50	5.78	10.30	9.41	2.8	165 LBS	JPM12FB	40	10
8	11.50	1.13	13.50	4 x 3/4-10 ∇ .79	4 x .88	11.75	7.48	12.54	9.41	2.8	230 LBS	JPM12FB	40	10
10	13.00	1.19	16.00	8 x 7/8-9 ∇ .79	4 x 1.00	14.25	8.88	14.02	10.08	3.9	340 LBS	JPM14B	53	13
12	14.00	1.26	19.00	8 x 7/8-9 ∇ .79	4 x 1.00	17.00	11.00	16.38	10.08	3.9	480 LBS	JPM14B	53	13
14	17.00	1.38	21.00	8 x 1-8 UNS ∇ 1.54	4 x 1.13	18.75	12.88	18.00	10.71	4.9	720 LBS	JPM15B	68	17
16	17.75	1.44	23.50	8 x 1-8 UNS ∇ 1.06	8 x 1.13	21.25	14.69	22.50	10.71	4.9	850 LBS	JPM15B	68	17

DRAWN	J CAPPER	3/28/2017	 M&H VALVE Division of McWane, Inc. 605 West 23rd Street, Anniston, Alabama 36201
CHECKED	DB	3/29/2017	
APPROVED			
TITLE: 3"-16" "FULL FLOW" FLG EPV 6412-FF w/ JPM Gear - DP NUT			REV 9
SIZE DWG. NO. D SUB910401T			

REVISIONS			
REV.	DESCRIPTION	BY	DATE
1	RELEASED	J CAPPER	9/26/17
2	CORRECTED COVER "SEAT" LETTERING	J CAPPER	9/27/2017
3	ADDED 304 SS OPTION TO FASTENER MATERIAL	J CAPPER	8/13/2018
4	UPDATED J DIM, MADE FASTENERS 316 SS STANDARD, EDITED MARKINGS NOTE	J CAPPER	2/25/2019
5	ADDED GEAR RATIO & # OF TURNS TO TABLE, ALSO UPDATED WITH CORRECT BODY BODY MARKINGS	CAW	3/26/2019

VALVE SIZE RANGE	WATER WORKING PRESSURE (PSI)	HYDROSTATIC TEST (PSI)
3-12"	175	350
14-16"	150	300

ITEM#	PART NAME	ASTM/ DESIGNATION	QTY.
1	LOWER SLEEVE BEARING	SINTERED ALLOY SS316	11
2	LOWER GRIT SEAL	NBR	1
3	LOWER THRUST WASHER	PTFE	1
4	PLUG	ASTM A536 GR.65-45-12 or GR.75-50-05 +NBR	1
5	BODY	ASTM A536 GR. 65-45-12 or 70-50-05	1
6	UPPER THRUST WASHER	PTFE	1
7	UPPER GRIT SEAL	NBR	1
8	UPPER SLEEVE BEARING	SINTERED ALLOY SS316	1
9	V-PACKING	NBR	1
10	FOLLOWER GLAND	ASTM A536 GR. 65-45-12 or 70-50-05	1
11	HEX NUTS	STAINLESS STEEL ASTM A276.T316	2
12	STUDS	STAINLESS STEEL ASTM A276.T316	2
13	ADAPTER	ASTM A536 GR. 65-45-12 or 70-50-05	1
14	ADAPTER BOLTS	STAINLESS STEEL ASTM A276.T316	6
15	COVER BOLTS	STAINLESS STEEL ASTM A276.T316	4
16	COVER	ASTM A536 GR. 65-45-12 or 70-50-05	1
17	COVER O-RING	NBR	1
18	JPM GEAR w/ DP NUT	-----	1
19	SLOT TYPE SPRING PIN	ASTM A29 1566	1

NOTE:
 * FOR SERVICES WITH 3"- 8" PLUG VALVES IN EXCESS OF 25 PSI, USE OF A GEAR IS RECOMMENDED.
 * GEAR MODEL AND BRAND ARE SUBJECT TO CHANGE WITHOUT NOTICE.

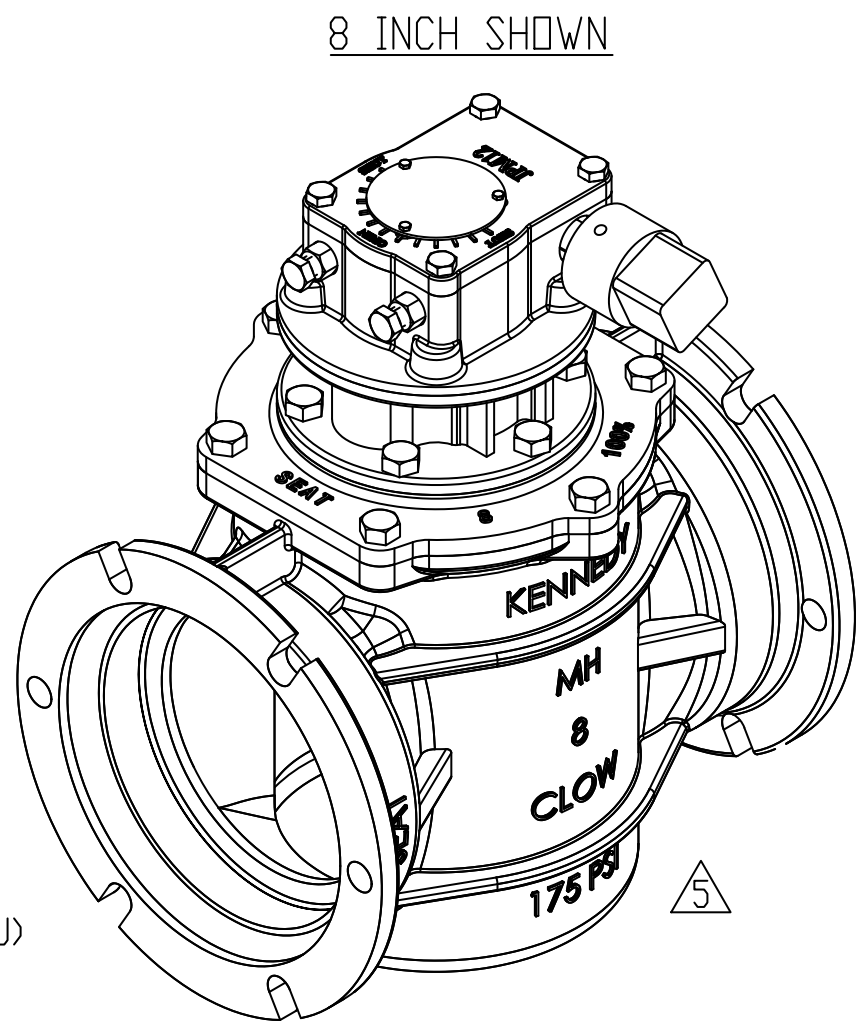
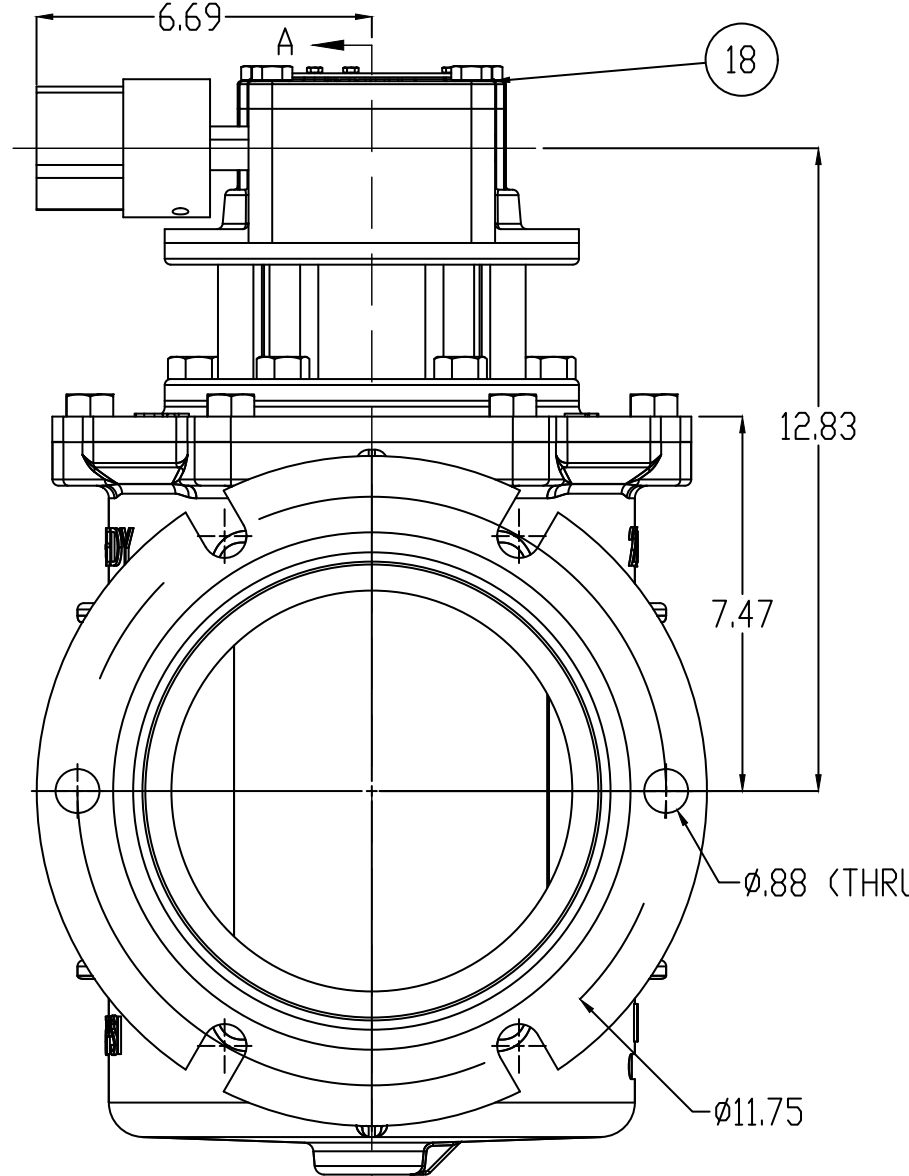
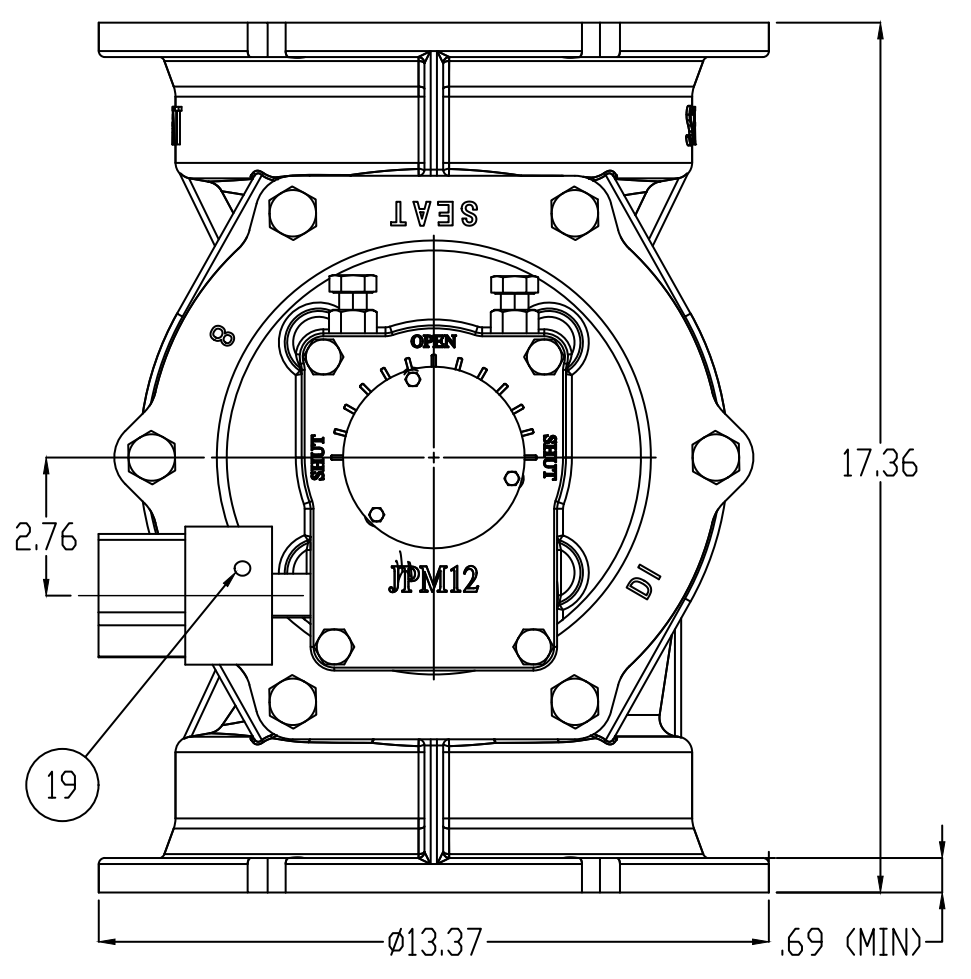

NOTE:
 1. BODY CASTINGS ARE TRI-MARKED WITH "CLOW," "KENNEDY," AND "M&H"

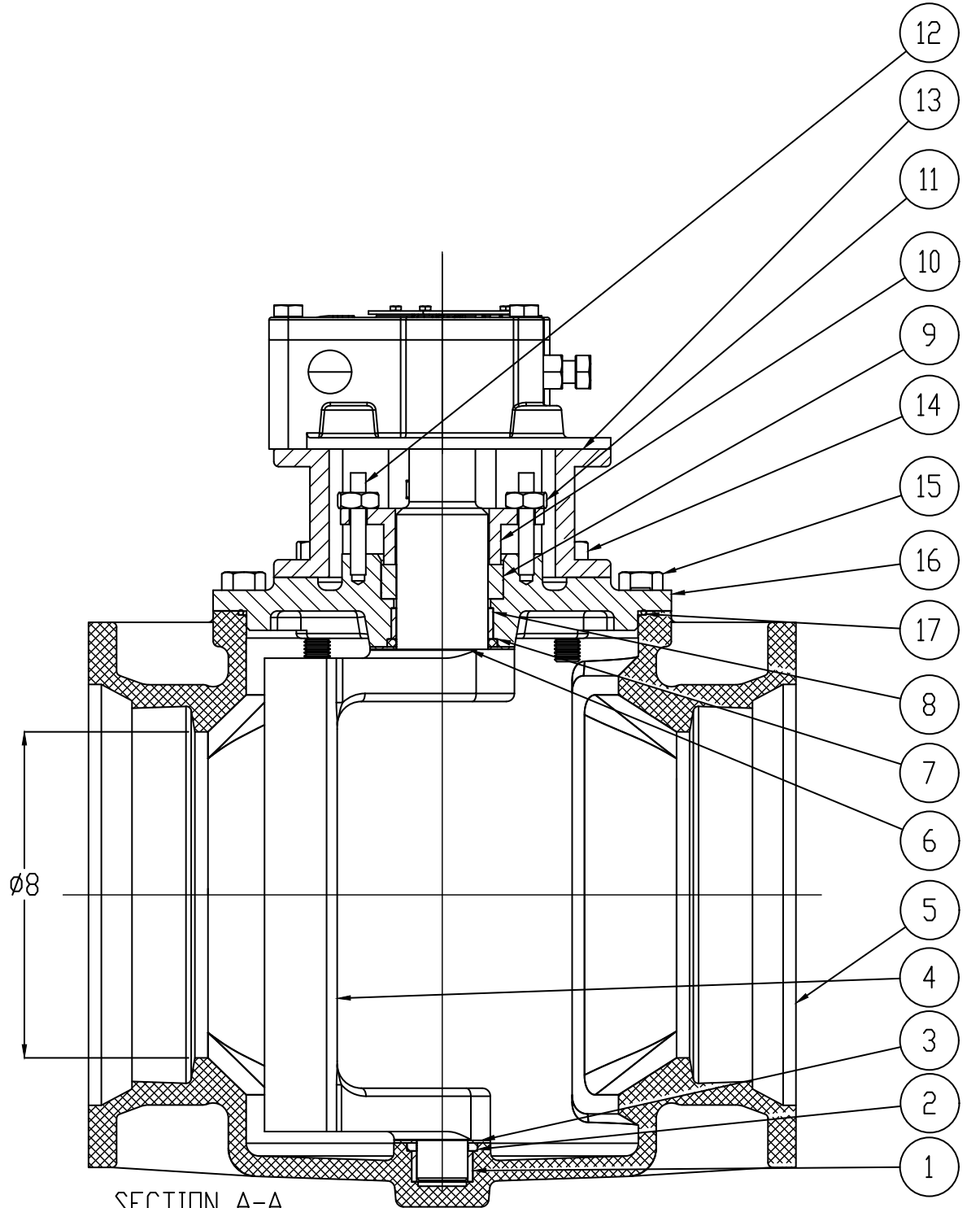

SECTION A-A
 SCALE 1 : 2.5

A VALVE SIZE	B	C	D	F	G	H	I	J	K	WEIGHT [LBS.]	JPM GEAR	GEAR RATIO	# OF TURNS TO OPEN (APPROX)
3	11.50	.58	Ø 7.62	4 x .75 THRU	Ø 6.19	3.76	7.50	9.01	2.8	75 LBS	JPM12B	40	10
4	14.25	.60	Ø 9.06	4 x .88 THRU	Ø 7.50	4.65	8.28	9.01	2.8	100 LBS	JPM12B	40	10
6	15.75	.63	Ø 11.06	6 x .88 THRU	Ø 9.50	5.78	10.30	9.41	2.8	165 LBS	JPM12FB	40	10
8	17.36	.66	Ø 13.39	6 x .88 THRU	Ø 11.75	7.48	12.54	9.41	2.8	230 LBS	JPM12FB	40	10
10	19.37	.70	Ø 15.62	8 x .88 THRU	Ø 14.25	8.88	14.02	10.08	3.9	340 LBS	JPM14B	53	13
12	20.75	.73	Ø 17.88	8 x .88 THRU	Ø 16.25	11.00	16.38	10.08	3.9	480 LBS	JPM14B	53	13
14	24.50	.79	Ø 20.25	10 x .88 THRU	Ø 18.75	12.88	18.00	10.71	4.9	720 LBS	JPM15B	68	17
16	27.25	.85	Ø 22.50	12 x .88 THRU	Ø 21.00	14.69	22.50	10.71	4.9	850 LBS	JPM15B	68	17

DRAWN	J CAPPER	9/26/17		M&H VALVE
CHECKED				Division of McWane, Inc.
APPROVED			605 West 23rd Street, Anniston, Alabama 36201	TITLE:
DO NOT SCALE DRAWING				3"-16" "FULL FLOW" MJ EPV NON-DOM
MATERIAL:	SEE TABLE			6412-FF w/ JPM Gear - DP NUT
Weight:	SEE TABLE			SIZE DWG. NO.
				D SUB910444T
				REV 5

PROPRIETARY AND CONFIDENTIAL
 THE INFORMATION CONTAINED IS THE SOLE PROPERTY OF M&H VALVE CO. ANY REPRODUCTION IN PART OR AS A WHOLE WITHOUT THE WRITTEN PERMISSION OF M&H VALVE CO. IS PROHIBITED. DESIGN & INVENTION RIGHTS RESERVED.

SHEET 1 OF 1

SIZE RANGE	WATER WORKING PRESSURE PSI	HYDROSTATIC TEST PSI
3-12	175 PSI	350 PSI

ITEM#	PART NAME	ASTM/ DESIGNATION	QTY.
1	LOWER SLEEVE BEARING	SINTERED ALLOY SS316	11
2	LOWER GRIT SEAL	NBR	1
3	LOWER THRUST WASHER	PTFE	1
4	PLUG	ASTM A536 GR.65-45-12 or GR.75-50-05 +NBR	1
5	BODY	ASTM A536 GR. 65-45-12 or 70-50-05	1
6	UPPER THRUST WASHER	PTFE	1
7	UPPER GRIT SEAL	NBR	1
8	UPPER SLEEVE BEARING	SINTERED ALLOY SS316	1
9	V-PACKING	NBR	1
10	BRAKE	PPS 40% GLASS FILLED	1
11	COVER STUDS	STAINLESS STEEL ASTM A276.T316	4
12	COVER STUD HEX NUTS	STAINLESS STEEL ASTM A276.T316	2
13	2" SQ. DP-NUT	ASTM A536 GR. 65-45-12 or 70-50-05	1
14	PLUG STEM STUD	STAINLESS STEEL ASTM A276.T316	1
15	HEX LOCKING NUT	STAINLESS STEEL ASTM A276.T316	1
16	DISC SPRING WASHER	STAINLESS STEEL ASTM A276.T316	5
17	COVER	ASTM A536 GR. 65-45-12 or 70-50-05	1
18	COVER O-RING	NBR	1
19	COVER BOLTS	STAINLESS STEEL ASTM A276.T316	4
20	HEX JAM NUT	STAINLESS STEEL ASTM A276.T316	1
21	FOLLOWER SQ. HEAD SET SCREW	STAINLESS STEEL ASTM A276.T316	1
22	SOCKET HEAD CAPSCREW	STAINLESS STEEL ASTM A276.T316	1
23	WASHER	STAINLESS STEEL ASTM A276.T316	1
24	HEX JAM NUT	STAINLESS STEEL ASTM A276.T316	1

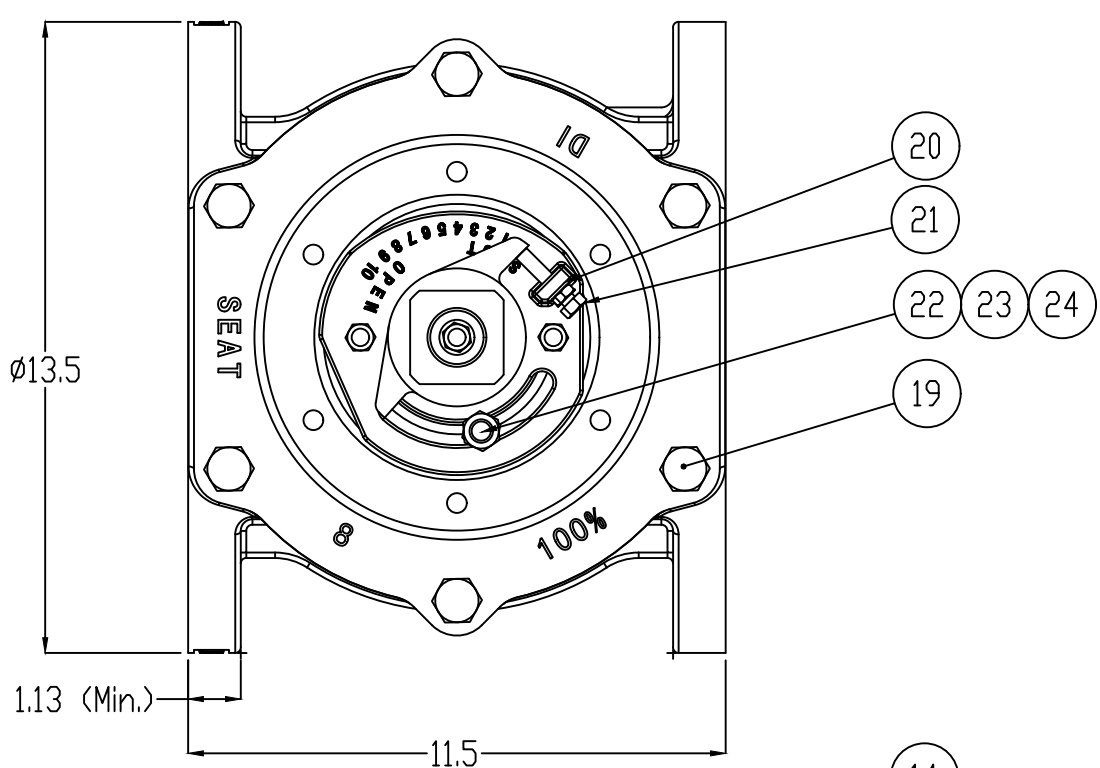

8 INCH SHOWN

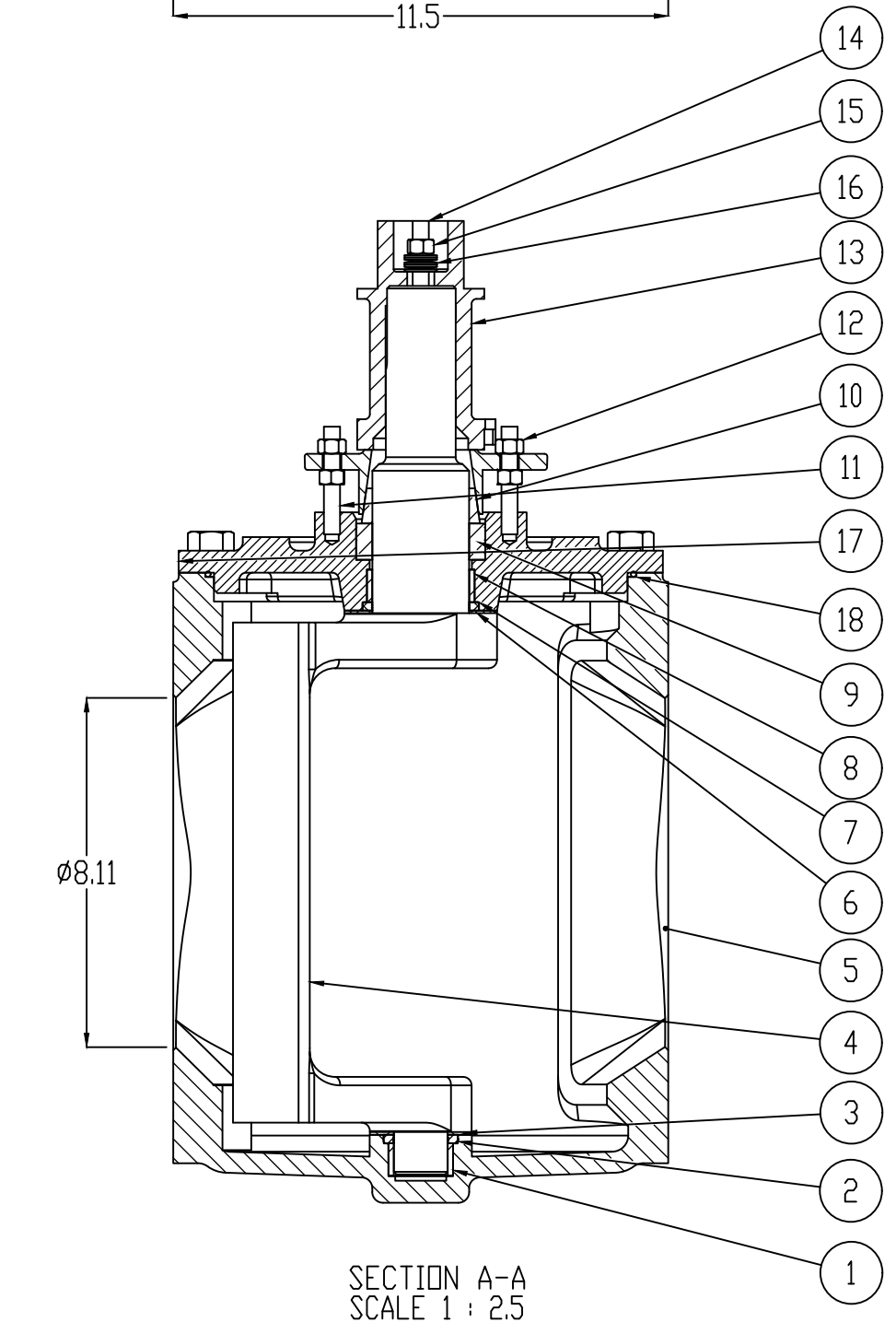
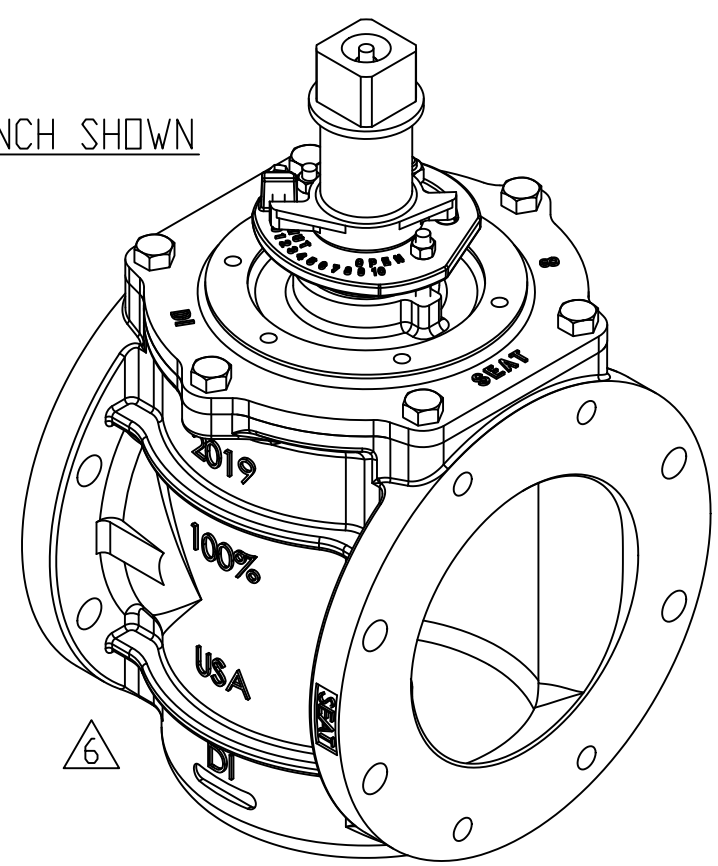

SECTION A-A
SCALE 1 : 2.5

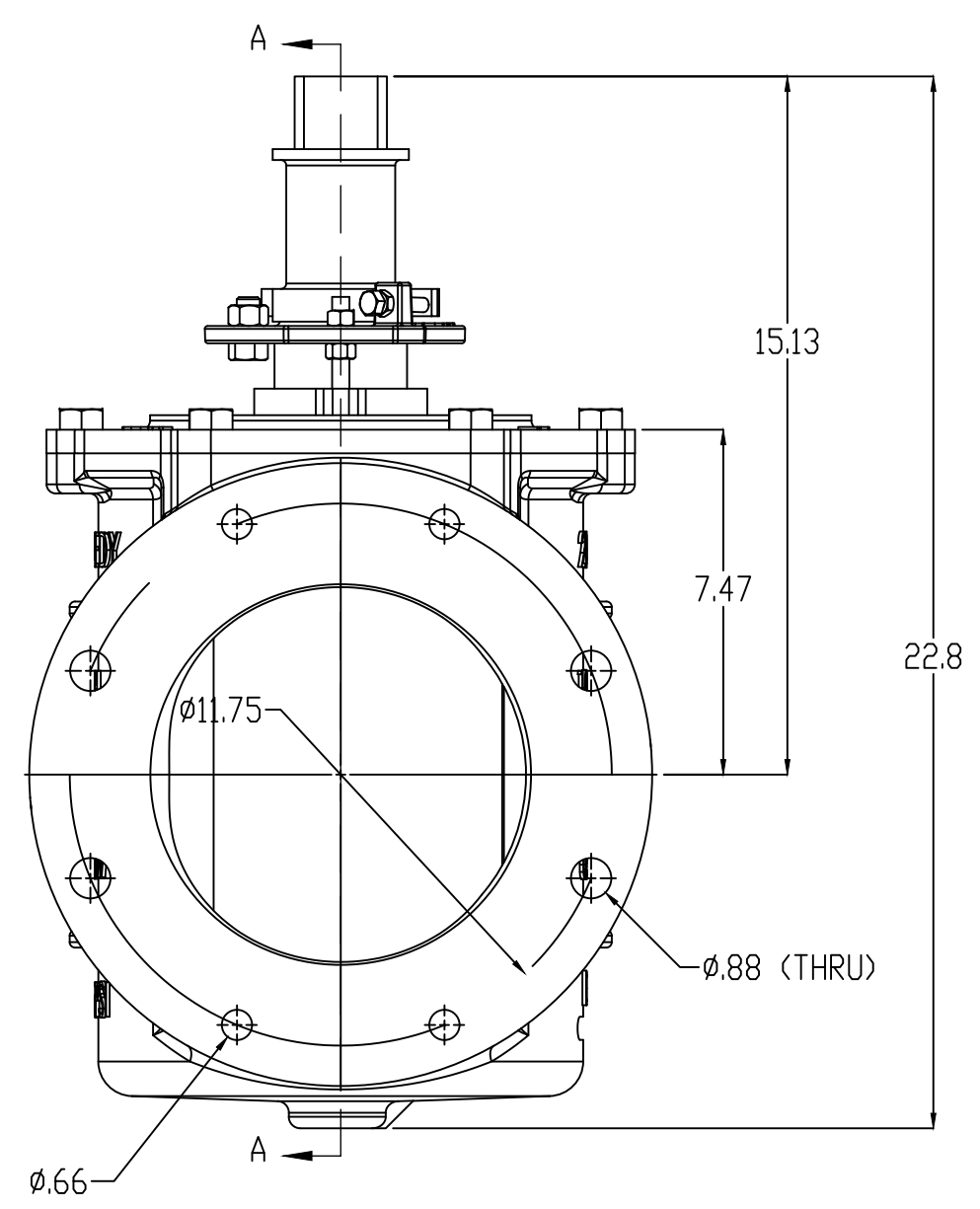

NOTE:
 1. BODY CASTINGS ARE TRI-MARKED WITH "CLOW," "KENNEDY," AND "M&H"
 2. 2" SQ. DP NUT ACCEPTS STANDARD 2" LEVER/WRENCH
 3. FOR SERVICES IN EXCESS OF 25 PSI USE OF A GEAR IS RECOMMENDED

A [VALVE SIZE]	B	C	D	E	F	G	H	I	J	WEIGHT [LBS.]
3	8.00	.75	7.50	4 x 5/8-11 ∇ .79	-	6.00	3.76	9.38	13.24	50 LBS
4	9.00	.94	9.00	4 x 5/8-11 ∇ .79	4 x .75	7.50	4.65	10.15	14.86	75 LBS
6	10.50	1.02	11.00	4 x 3/4-10 ∇ .79	4 x .81	9.50	5.78	12.96	18.75	125 LBS
8	11.50	1.13	13.50	4 x 3/4-10 ∇ .79	4 x .88	11.75	7.48	15.13	22.79	185 LBS

REV.	DESCRIPTION	BY	DATE
2	ADDED 316SS FASTENERS TO BOM AND ADDED NOTE PER CUSTOMER REQUEST	CAW	9/11/2015
3	ATTACHED LEVER	ML	10/8/2015
4	ADDED LEVER OPTION NOTE, PRESSURE NOTE	J CAPPER	7/26/2018
5	MADE FASTENERS 316SS STANDARD, EDITED MARKING NOTE	J CAPPER	2/26/2019
6	UPDATED WITH CORRECT BODY MARKINGS	CAW	3/26/2019

DRAWN	NAME	DATE		M&H VALVE	
CHECKED	CAW	7/15/2015		Division of McWane, Inc.	
APPROVED	ML	8/7/2015	605 West 23rd Street, Anniston, Alabama 36201		TITLE:
DO NOT SCALE DRAWING			3'-8" "FULL FLOW" FLG EPV (6412-FF) w/ 2" DP-NUT (LEVER OPTION)		REV
MATERIAL: SEE TABLE			SIZE	DWG. NO.	6
WEIGHT: SEE TABLE			D	SUB910245T	
<small>PROPRIETARY AND CONFIDENTIAL THE DESIGN OR CONTAINER IS THE SOLE PROPERTY OF M&H VALVE CO. ANY REPRODUCTION IN PART OR AS A WHOLE WITHOUT THE WRITTEN PERMISSION OF M&H VALVE CO. IS PROHIBITED. DESIGN & INVENTION RIGHTS RESERVED.</small>					

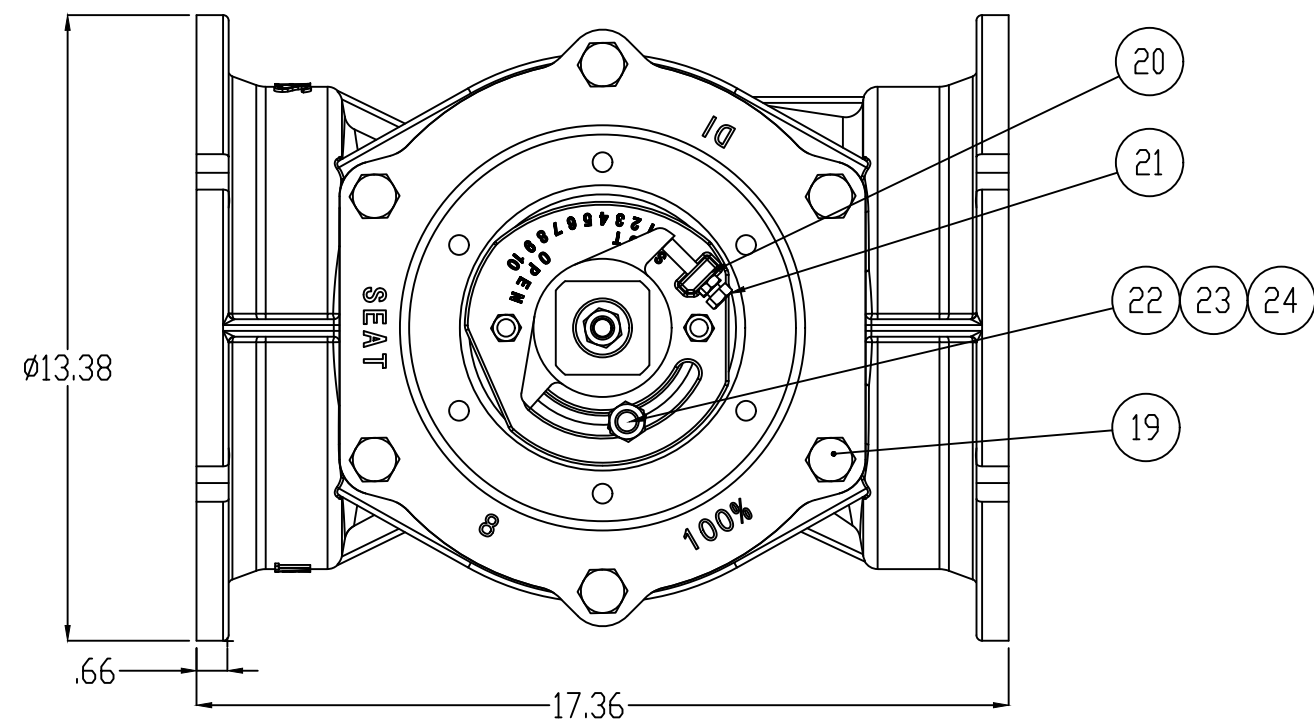

8 INCH SHOWN

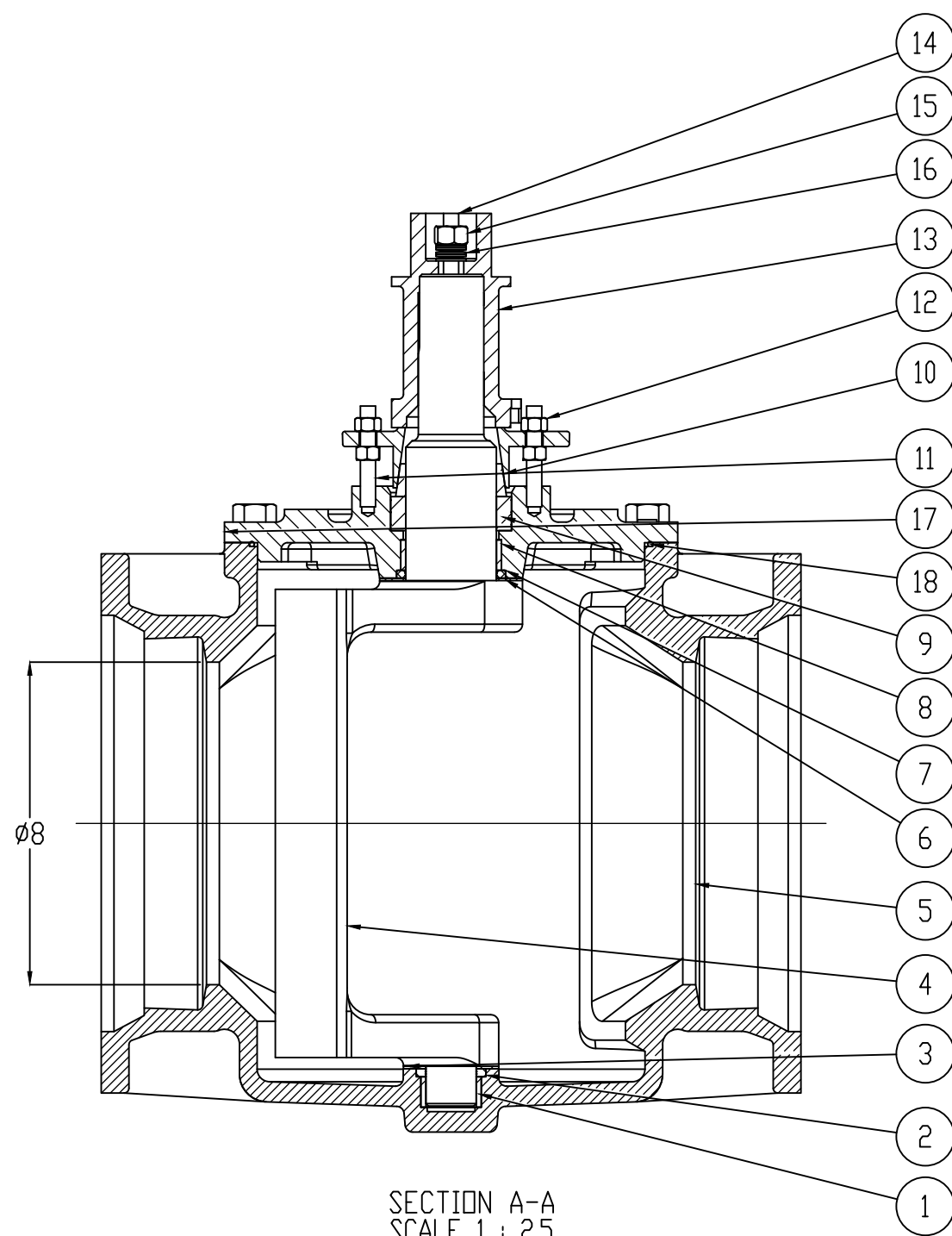
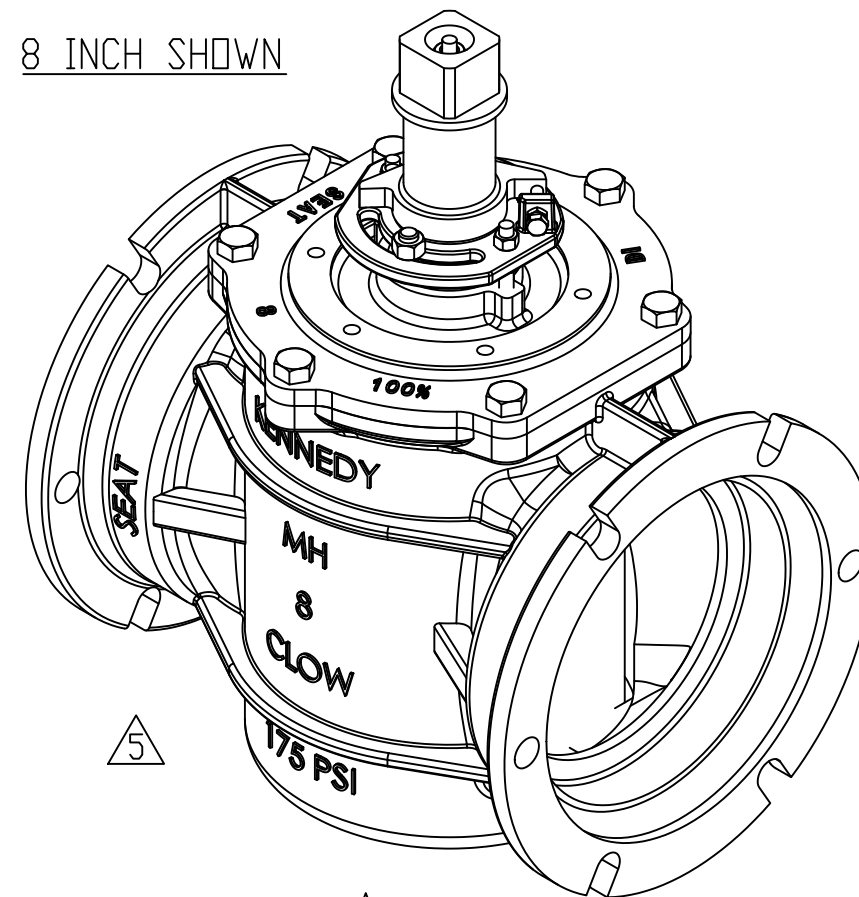

SECTION A-A
SCALE 1 : 2.5

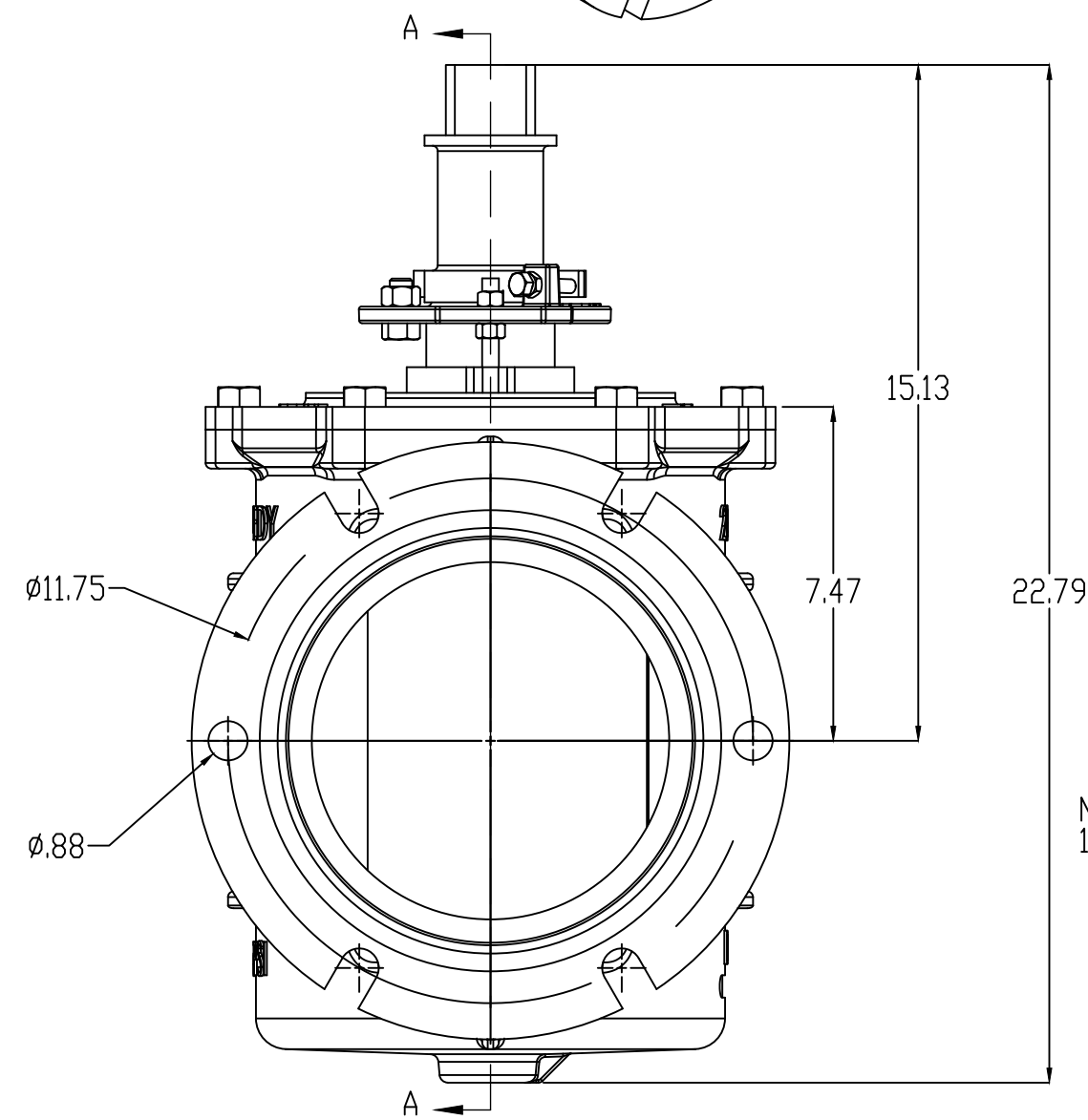

NOTE: FOR SERVICES IN EXCESS OF 25 PSI, USE OF A GEAR IS RECOMMENDED

ITEM#	PART NAME	ASTM/ DESIGNATION	QTY.
1	LOWER SLEEVE BEARING	SINTERED ALLOY SS316	11
2	LOWER GRIT SEAL	NBR	1
3	LOWER THRUST WASHER	PTFE	1
4	PLUG	ASTM A536 GR.65-45-12 or GR.75-50-05 +NBR	1
5	BODY	ASTM A536 GR. 65-45-12 or 70-50-05	1
6	UPPER THRUST WASHER	PTFE	1
7	UPPER GRIT SEAL	NBR	1
8	UPPER SLEEVE BEARING	SINTERED ALLOY SS316	1
9	V-PACKING	NBR	1
10	BRAKE	PPS 40% GLASS FILLED	1
11	COVER STUDS	STAINLESS STEEL ASTM A276.T316	4
12	COVER STUD HEX NUTS	STAINLESS STEEL ASTM A276.T316	2
13	2" SQ. OP-NUT	ASTM A536 GR. 65-45-12 or 70-50-05	1
14	PLUG STEM STUD	STAINLESS STEEL ASTM A276.T316	1
15	HEX LOCKING NUT	STAINLESS STEEL ASTM A276.T316	1
16	DISC SPRING WASHER	STAINLESS STEEL ASTM A276.T316	5
17	COVER	ASTM A536 GR. 65-45-12 or 70-50-05	1
18	COVER O-RING	NBR	1
19	COVER BOLTS	STAINLESS STEEL ASTM A276.T316	4
20	HEX JAM NUT	STAINLESS STEEL ASTM A276.T316	1
21	FOLLOWER SQ. HEAD SET SCREW	STAINLESS STEEL ASTM A276.T316	1
22	SOCKET HEAD CAPSCREW	STAINLESS STEEL ASTM A276.T316	1
23	WASHER	STAINLESS STEEL ASTM A276.T316	1
24	HEX JAM NUT	STAINLESS STEEL ASTM A276.T316	1

NOTE:
1. BODY CASTINGS ARE TRI-MARKED WITH "CLOW," "KENNEDY," AND "M&H"

REVISIONS			
REV.	DESCRIPTION	BY	DATE
2	ADDED 316SS FASTENERS TO BOM AND ADDED NOTE PER REQUEST CUSTOMER REQUEST	CAW	9/1/2015
3	ADDED PRESSURE NOTE	J CAPPER	7/26/2018
4	MADE FASTENERS 316SS STANDARD, EDITED MARKINGS NOTE	J CAPPER	2/26/2019
5	UPDATED WITH CORRECT BODY MARKINGS	CAW	3/26/2019

DRAWN	CAW	DATE	7/20/2015	 M&H VALVE Division of McWane, Inc. 605 West 23rd Street, Anniston, Alabama 36201
CHECKED	ML	DATE	8/8/2015	
APPROVED		TITLE:	3'-8" "FULL FLOW" MJ EPV (6413-FF) w/ 2" OP-NUT	
DO NOT SCALE DRAWING			SIZE	DWG. NO.
MATERIAL: SEE TABLE			D	SUB910208T
WEIGHT: SEE TABLE				REV 5

A [VALVE SIZE]	B	C	D	F	G	H	I	J	WEIGHT [LBS.]
3	11.50	.58	Ø 7.62	4 x .75 THRU	Ø 6.19	3.76	9.38	13.24	70 LBS
4	14.25	.60	Ø 9.06	4 x .88 THRU	Ø 7.50	4.65	10.15	14.86	100 LBS
6	15.75	.63	Ø 11.06	6 x .88 THRU	Ø 9.50	5.78	12.96	18.75	145 LBS
8	17.36	.66	Ø 13.39	6 x .88 THRU	Ø 11.75	7.48	15.13	22.79	200 LBS

SIZE RANGE	WATER WORKING PRESSURE PSI	HYDROSTATIC TEST PSI
3-12	175 PSI	350 PSI

GEARBOX FOR BURIED SERVICE WILL NOT HAVE POSITION INDICATOR

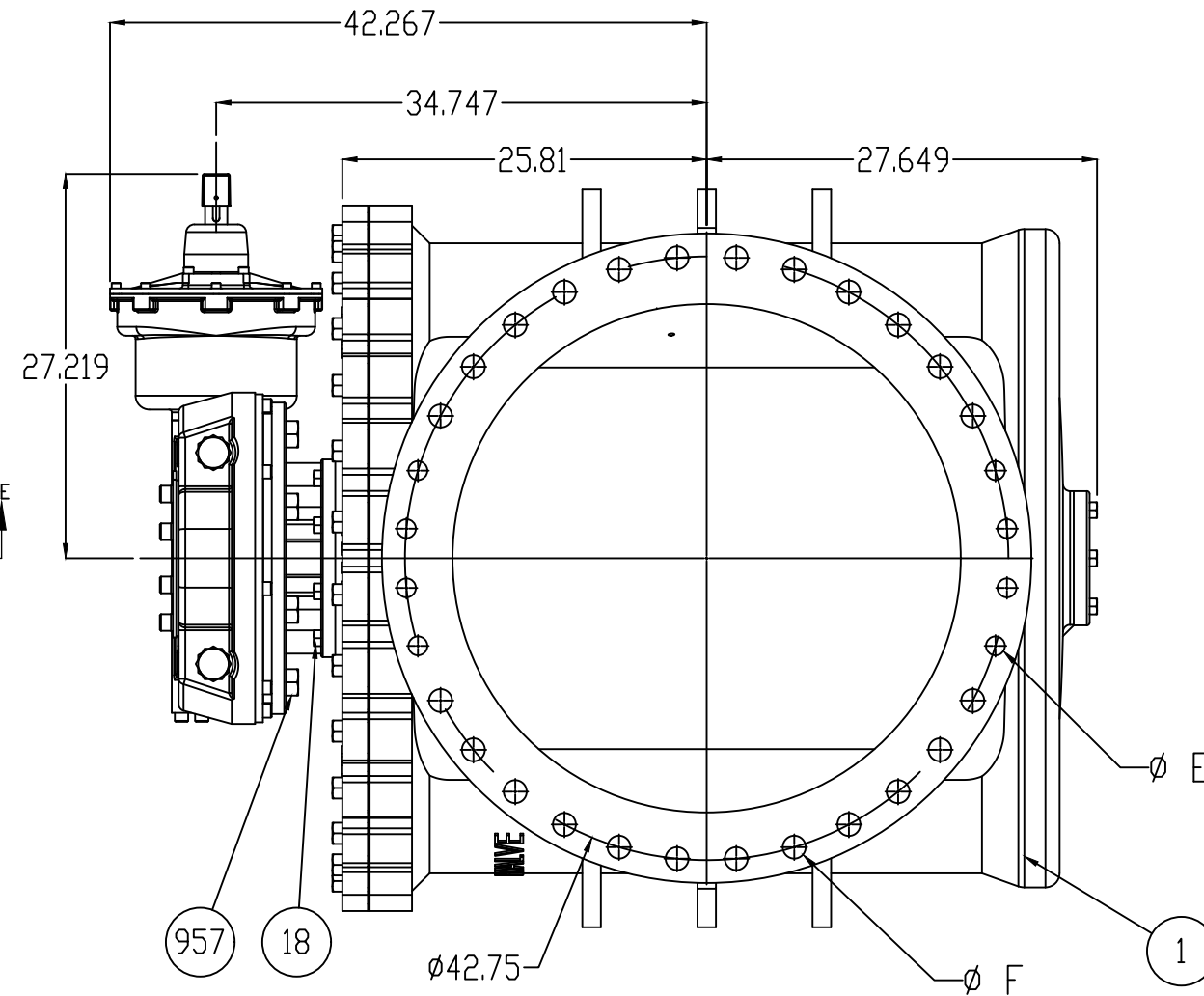
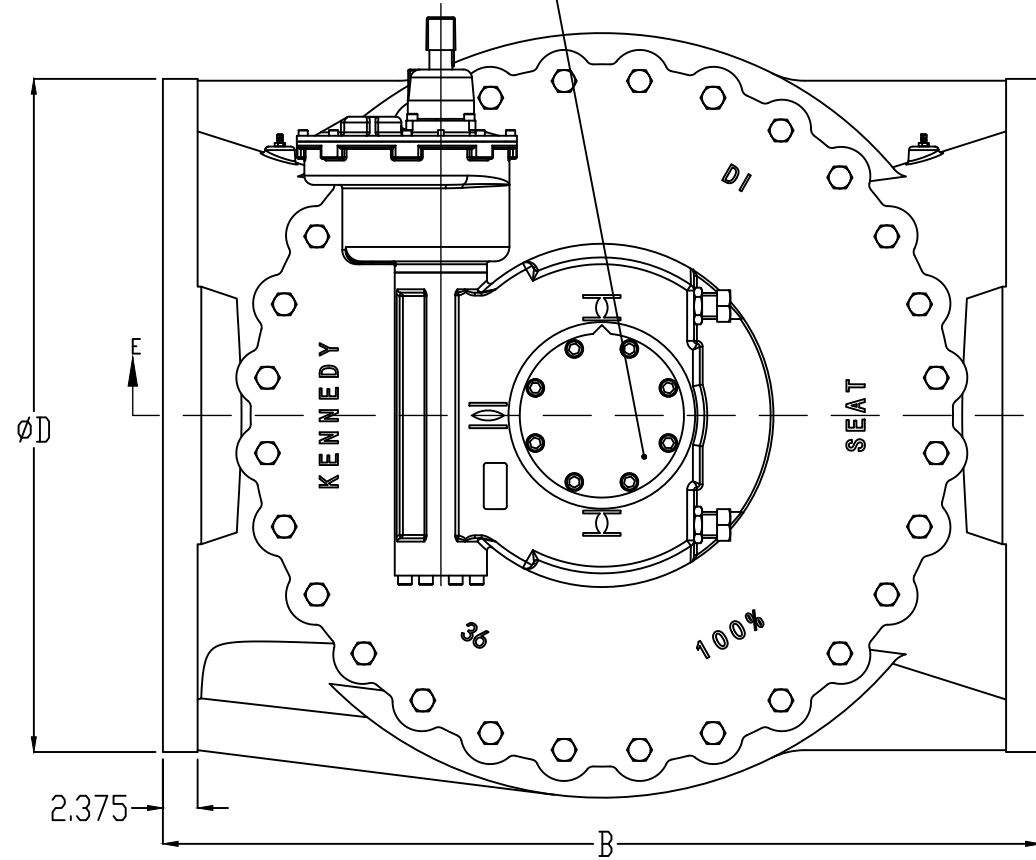

ITEM NO.	DESCRIPTION	MATERIAL
1	BODY - FLANGED	ASTM A536 GR. 65-45-12 DR 70-50-05
2	PLUG	ASTM A536 GR. 65-45-12 DR 70-50-05+NBR
3	COVER	ASTM A536 GR. 65-45-12 DR 70-50-05
4	BOTTOM THRUST WASHER	PTFE
5	BOTTOM BEARING	SINTERED ALLOY SS316
6	GRIT GUARD SHAFT SEAL (LOWER)	NBR
7	GRIT GUARD SHAFT SEAL (UPPER)	NBR
8	UPPER THRUST WASHER	PTFE
9	UPPER BEARING	SINTERED ALLOY SS316
10	V2-PACKING-AN6225-55	NBR
11	V2-TOP-PACKING-AN6225-55	NBR
12	V-BOTTOM-PACKING-AN6225-55	NBR
13	FP GLAND (FOR ACTUATOR)	ASTM A536 GR. 65-45-12 DR 70-50-05
14	BOTTOM COVER	ASTM A536 GR. 65-45-12 DR 70-50-05
15	COVER STUDS	STAINLESS STEEL ASTM A276.T316
16	HEXAGON COVER BOLTS	STAINLESS STEEL ASTM A276.T316
17	BOTTOM COVER BOLTS	STAINLESS STEEL ASTM A276.T316
18	HEXAGON ADAPTER BOLTS	STAINLESS STEEL ASTM A276.T316
19	HEX NUT	STAINLESS STEEL ASTM A276.T316
20	O-RING - BOTTOM COVER	NBR
21	O-RING - TOP COVER	NBR
22	FP ADAPTER - CLOSE	ASTM A536 GR. 65-45-12 DR 70-50-05
957	GEAR BOLTS	STAINLESS STEEL ASTM A276.T316

- NOTE:
- Interior and exterior ferrous metal surfaces are epoxy-coated.
 - Only 30" and 36" valves have a bottom cover plate (see pentagon ballon items).
 - Mount in orientation shown for buried service.
 - Gearbox for buried service will not have position indicator.
 - Body castings are tri-marked with "Clow," "Kennedy," and "M&H".

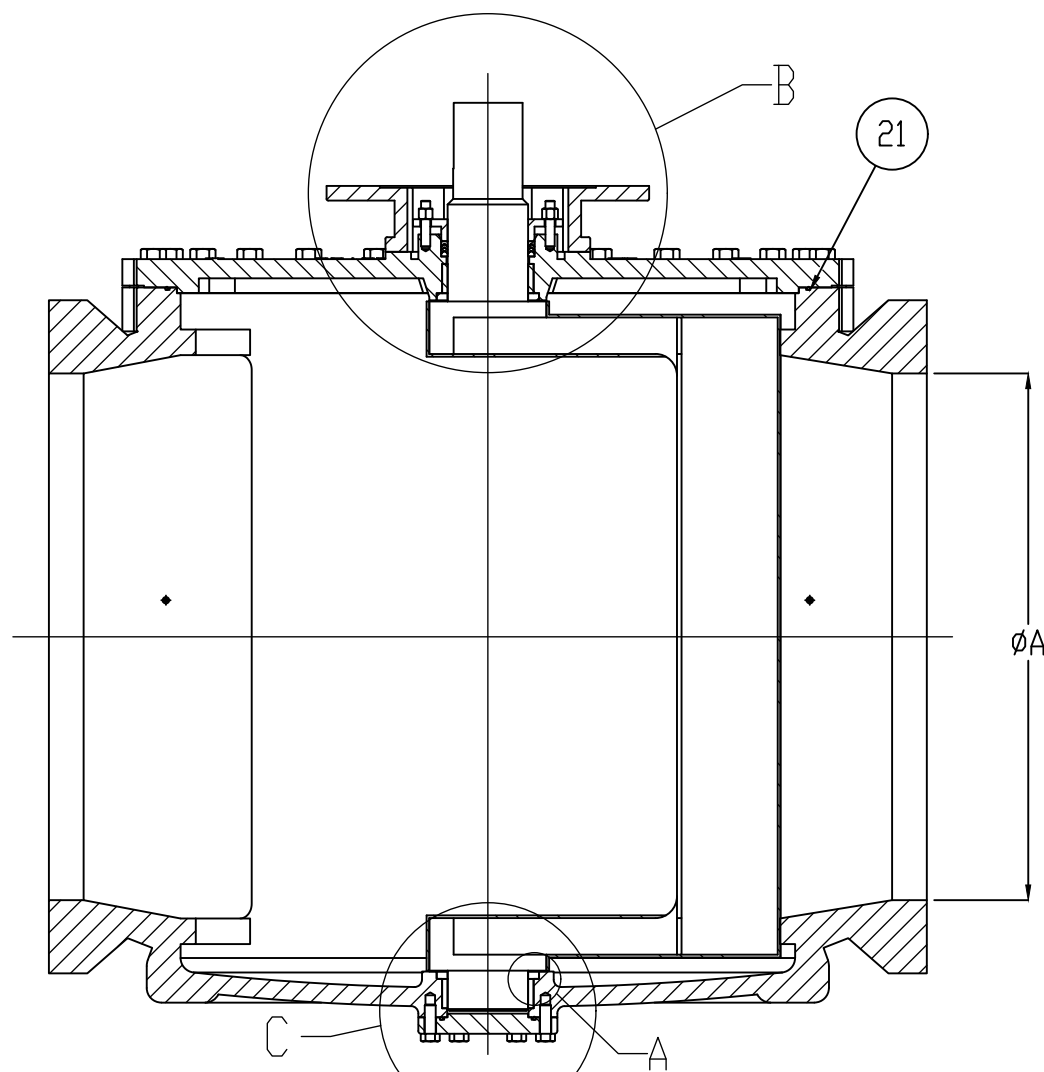

RECOMMENDED ORIENTATION FOR BURIED SERVICE:

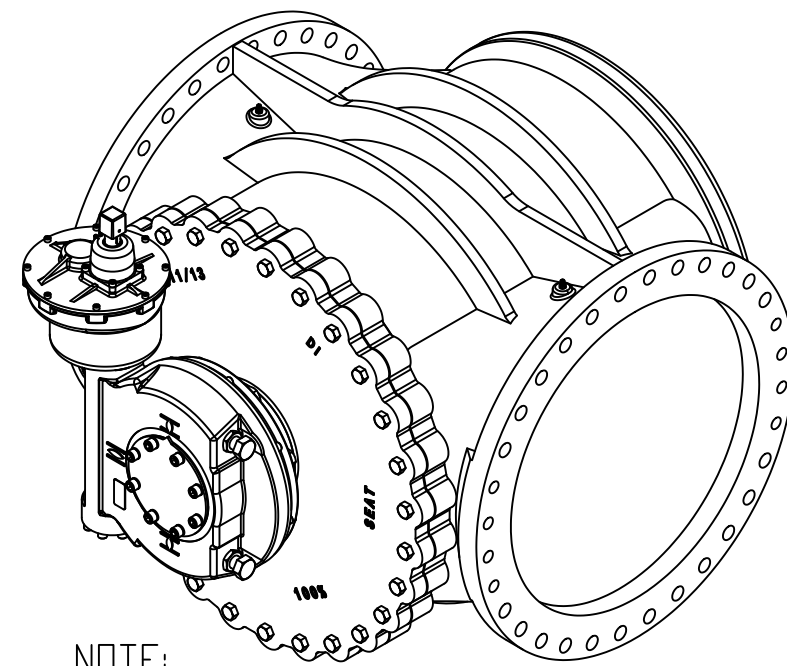

NOTE:
 ° 36" VALVE SHOWN
 ° SHOWN OPEN WITH PLUG UP

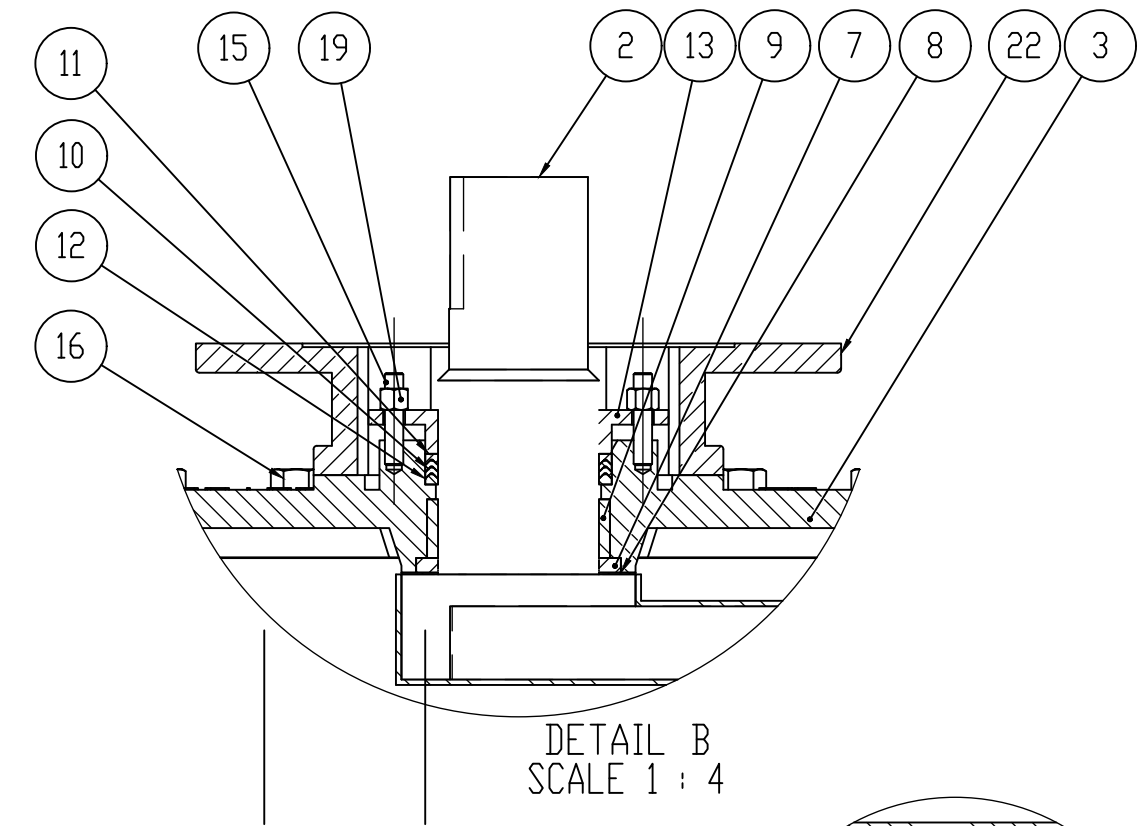

DETAIL B
SCALE 1 : 4

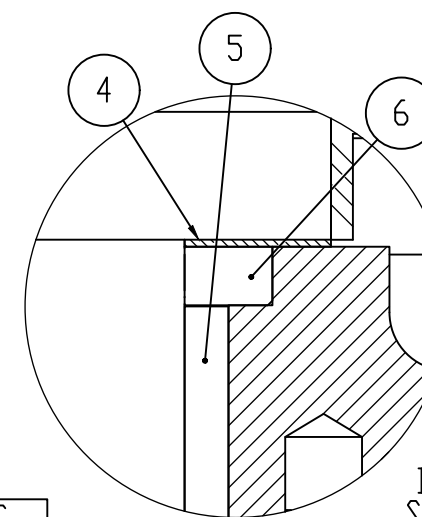

DETAIL A
SCALE 1 : 1

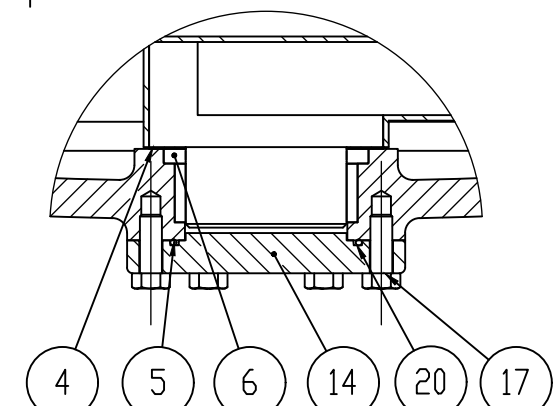

DETAIL C
SCALE 1 : 4

A [VALVE SIZE]	B	C	D	E	F	G	H	I	J	K	L	WEIGHT [LBS]	ROTORK GEAR	GEAR RATIO	TURNS TO OPEN (APPROX)	RATED PRESSURE	HYDROSTATIC TEST PRESSURE
18	21.50	1.58	Ø 25.00	8 x 1.13-7 UNS-2B ▽1.50	8 x Ø 1.25 THRU	Ø 22.75	16.42	22.7	27.6	15.5	18.3	1262	IW6 AWWA-IP68	152:1	38	150 PSI	300 PSI
20	23.50	1.69	Ø 27.50	8 x 1.13-7 UNS-2B ▽1.25	12 x Ø 1.25 THRU	Ø 25.00	17.09	23.7	28.6	15.5	17.4	1537	IW6 AWWA-IP68	228:1	57		
24	42.00	1.88	Ø 32.00	8 x 1.25-7 UNS-2B ▽2.00	12 x Ø 1.38 THRU	Ø 29.20	21.06	27.4	35.4	21.6	21.8	3421	IW7 AWWA-IP68	384:1	96		
30	51.00	2.13	Ø 38.75	8 x 1.25-7 UNS-2B ▽2.63	20 x Ø 1.38	Ø 36.00	22.19	30.3	37.2	27.2	22.5	6135	IW9 AWWA-IP68	696:1	174		
36	60.00	2.38	Ø 46.00	8 x 1.50-6 UNS-2B ▽3.50	36 x Ø 1.63 THRU	Ø 42.75	25.81	34.7	42.27	27.2	27.7	8515	IW9 AWWA-IP68	928:1	232		

REV.	DESCRIPTION	APPROVED	DATE
1	RELEASED	ML	11/13/15
2	CHANGE DETAIL A VIEW SIZE. REMOVE OPTION TEXT FROM NOTES	ML	11/24/2015
3	EDITED GEAR INFORMATION	J CAPPER	7/24/2018
4	MAKE FASTENERS 316 SS STANDARD. REMOVED 14"-16" SIZES. REMOVED 14" ADDED DIM JKLL. EDITED NOTES. UPDATED GEAR INFORMATION.	DPB, J CAPPER	2/19/19
5	FIXED ORIENTATIONS. ADDED J, K, L. REMOVED SIZES 14 & 16. UPDATED NOTE	CAV	3/20/2019
6	ADDED TRI-MARKING NOTE	J CAPPER	4/8/2019

NAME	DATE	TITLE
ML	11/13/2015	18"-36" "FULL FLOW" FLG EPV (6412-FF)
ML	11/13/2015	w/ ROTORK GEAR for Bury Service
ML	11/13/2015	SIZE DWG. NO. SUB910257T
ML	11/13/2015	REV 6

PROPRIETARY AND CONFIDENTIAL
 THE DESIGNER ASSUMES NO LIABILITY FOR THE USE OF THIS VALVE IN ANY MANNER OTHER THAN THAT FOR WHICH IT WAS DESIGNED. M&H VALVE COMPANY, AN IRVING-CLOUD COMPANY, IRVING, TEXAS 75039-1000. SHEET 1 OF 1

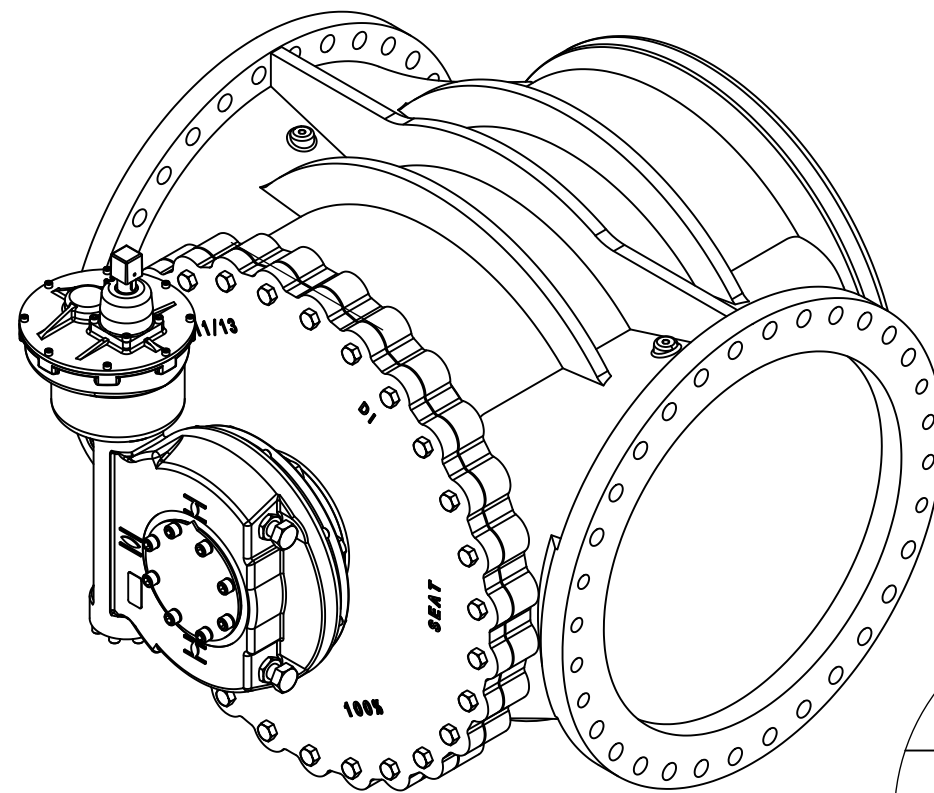
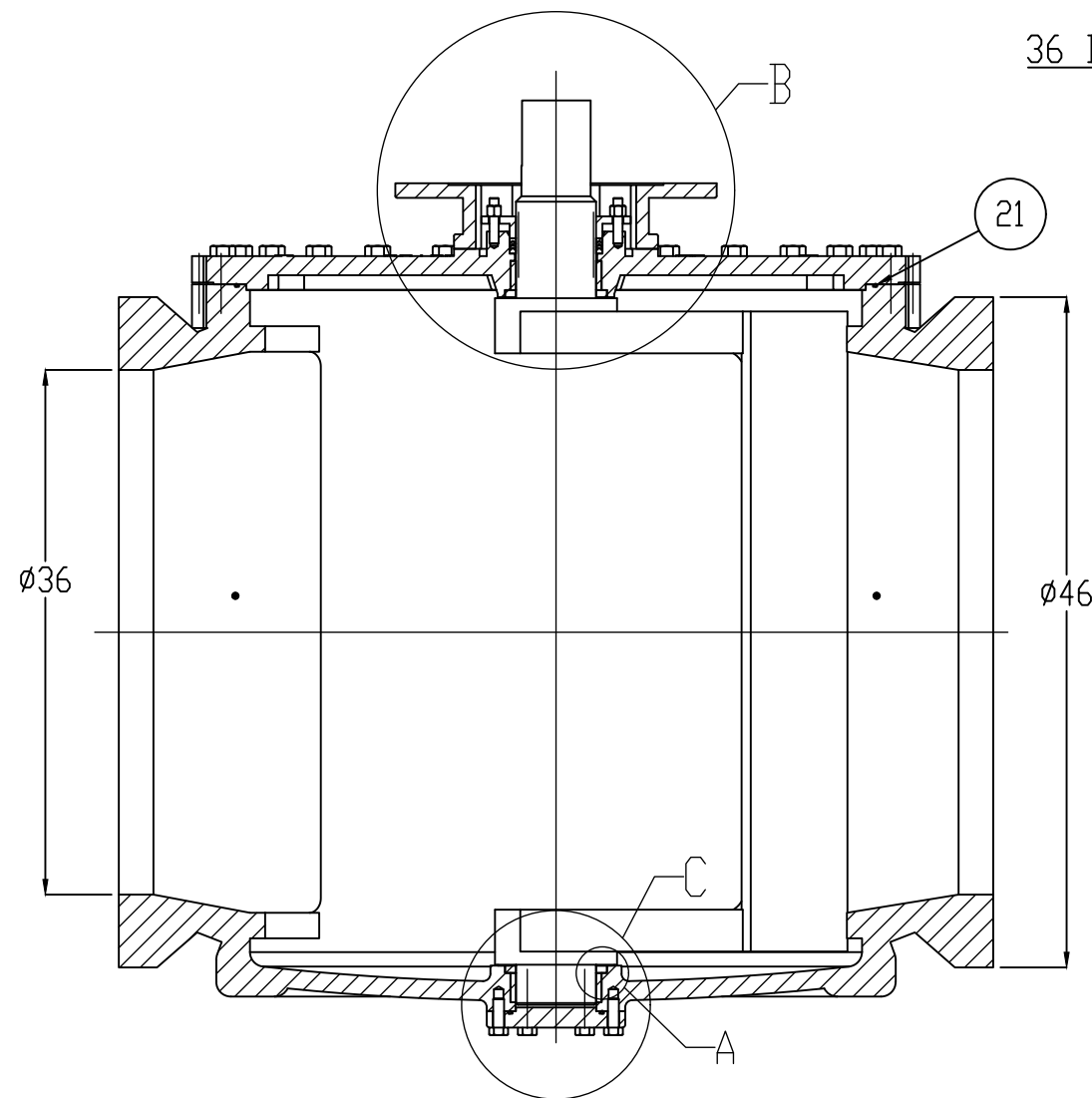
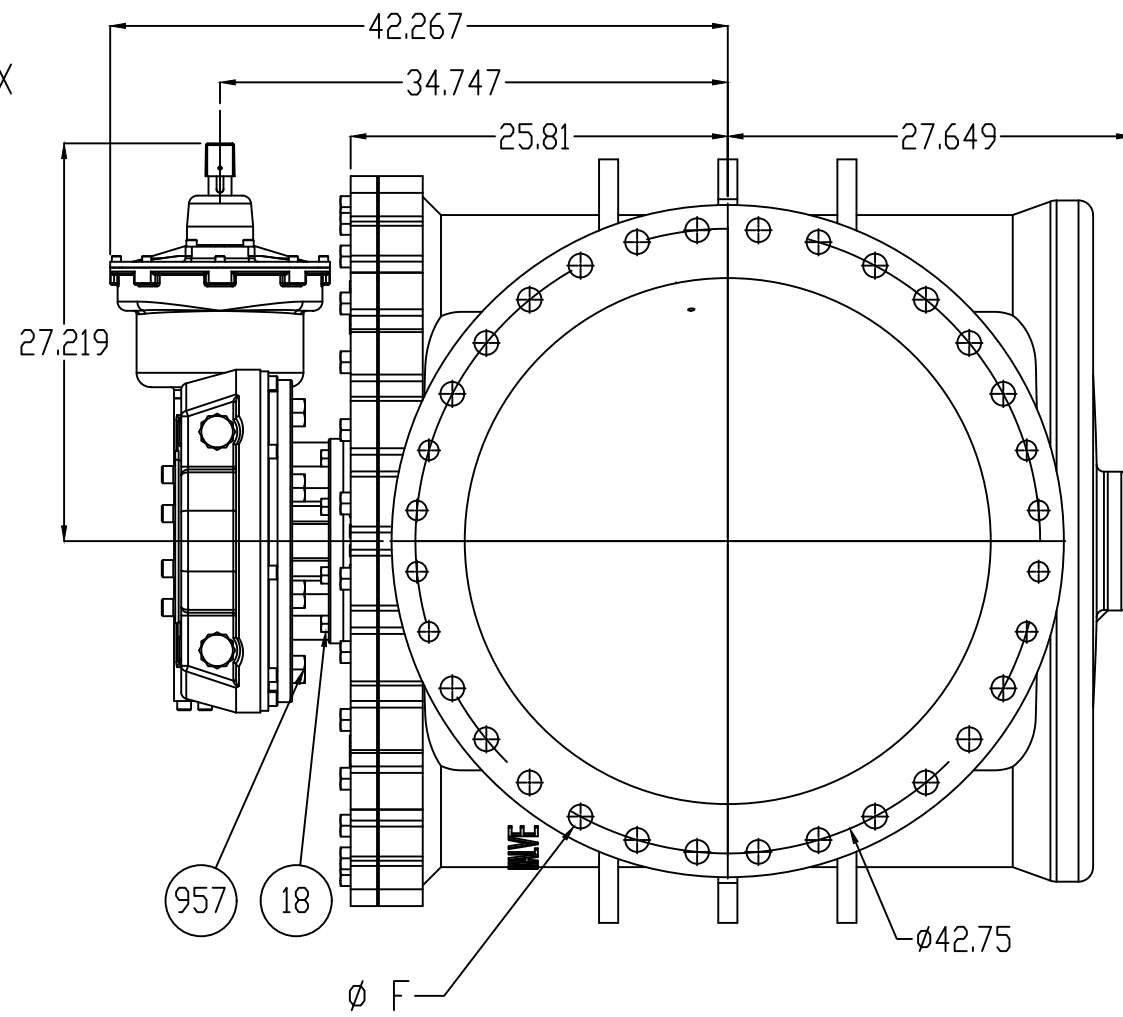
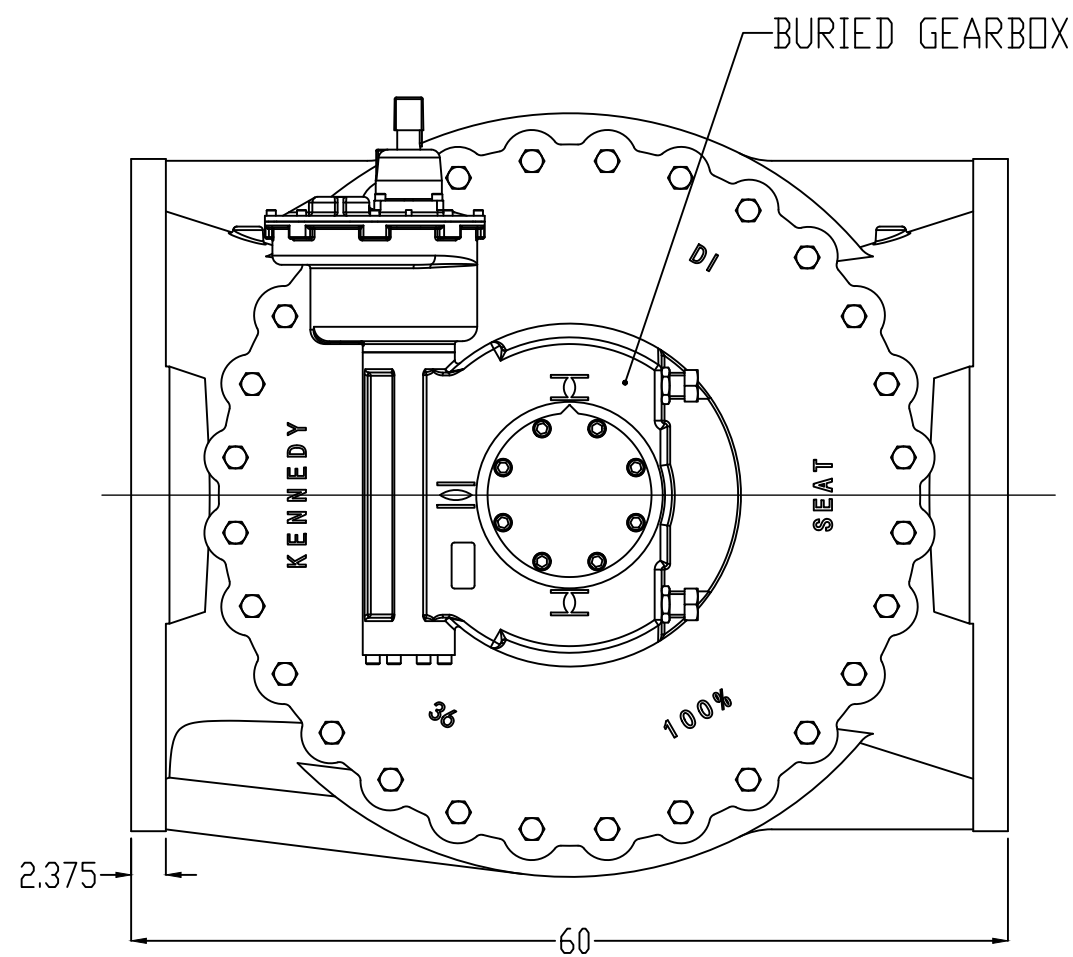

-SHOWN OPEN WITH PLUG UP
-RECOMMENDED ORIENTATION
FOR BURIED SERVICE

DETAIL A
SCALE 1 : 1

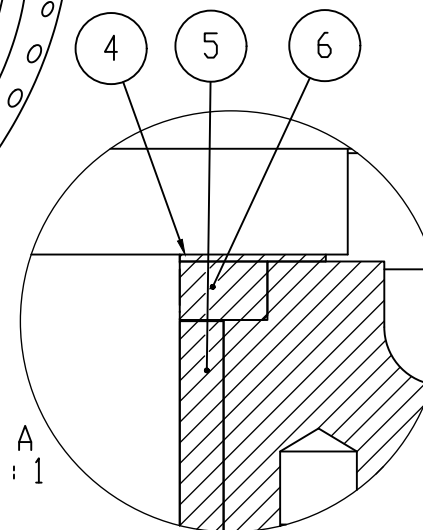

DETAIL B
SCALE 1 : 4

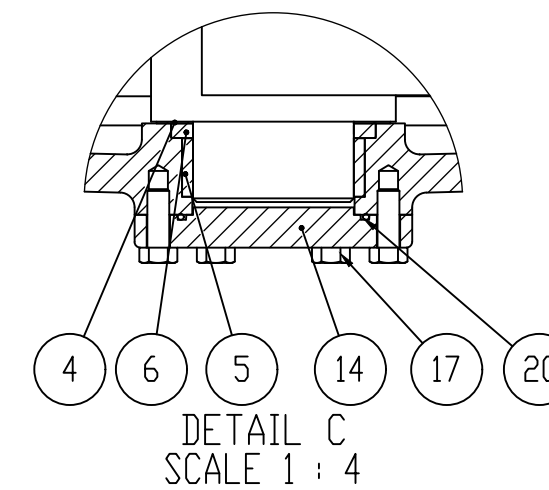
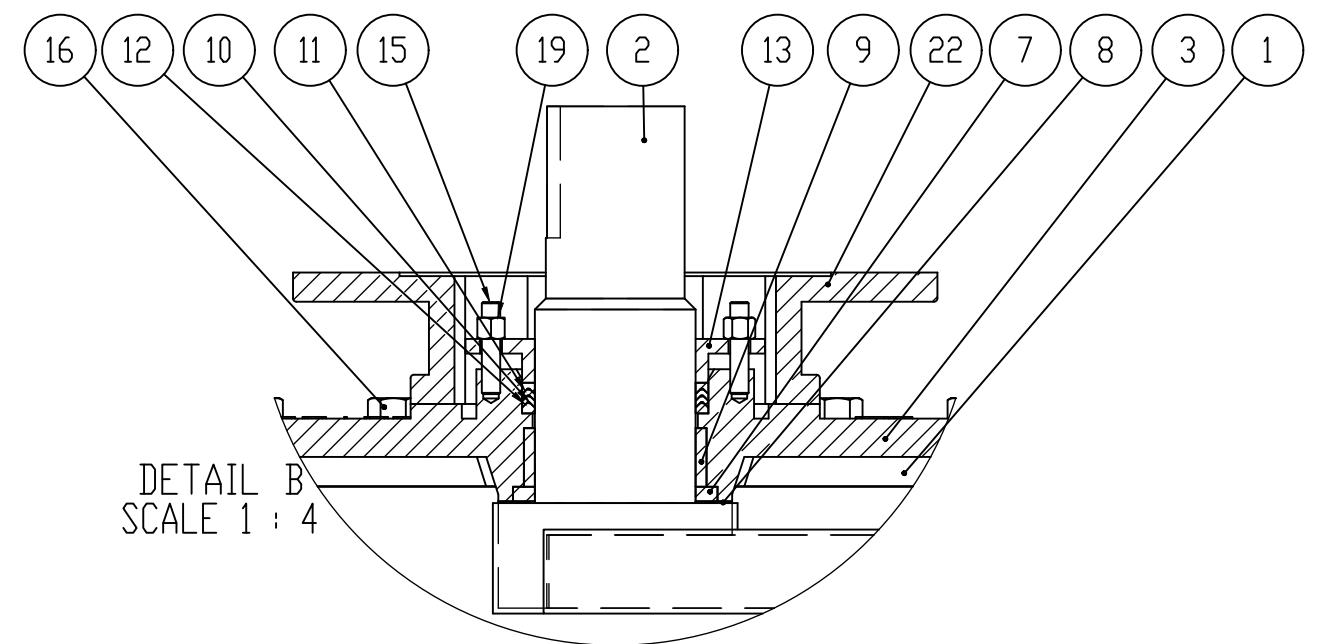

DETAIL C
SCALE 1 : 4

ITEM NO.	PART NUMBER	DESCRIPTION
1	Body-MJ	ASTM A536 Gr. 65-45-12 or 70-50-05
2	Plug I Rubber Coating	ASTM A536 Gr. 65-45-12 or 70-50-05 I NBR
3	Cover	ASTM A536 Gr. 65-45-12 or 70-50-05
4	Bottom Thrust	PTFE
5	Bottom Bearing	Sintered Alloy SS316
6	Grit Guard Shaft Seal (Lower)	NBR
7	Grit Guard Shaft Seal (Upper)	NBR
8	Upper Thrust	PTFE
9	Upper Bearing	Sintered Alloy SS316
10	V2-Packing-AN6225-55	NBR
11	V2-Top-Packing-AN6225-55	NBR
12	V-Bottom-Packing-AN6225-55	NBR
13	FP Gland (for Actuator)	ASTM A536 Gr. 65-45-12 or 70-50-05
14	Bottom Cover	ASTM A536 Gr. 65-45-12 or 70-50-05
15	Cover Studs	Stainless Steel ASTM A276.T316
16	Hexagon Cover Bolts	Stainless Steel ASTM A276.T316
17	Bottom Cover Bolts	Stainless Steel ASTM A276.T316
18	Hexagon Adaptor Bolts	Stainless Steel ASTM A276.T316
19	Cover Stud Hex Nut	Stainless Steel ASTM A276.T316
20	O-ring Bottom Cover	NBR
21	O-Ring Top Cover	NBR
22	FP Adaptor-Close	ASTM A536 Gr. 65-45-12 or 70-50-05
957	Gear Bolts	Stainless Steel ASTM A276 T316

- NOTE:
1. Interior and exterior ferrous metal surfaces are epoxy-coated
 2. Only 30" and 36" valves have a bottom cover plate (see pentagon ballon items)
 3. Mount in orientation shown for buried service
 4. Gearbox for buried service will not have position indicator
 5. Body castings are tri-marked with "Clow," "Kennedy," and "M&H"

A (VALVE SIZE)	B	C	D	F	G	H	I	J	K	L	WEIGHT (LBS)	ROTOR GEAR	GEAR RATIO	TURNS TO OPEN (APPROX)	WATER WORKING PRESSURE (PSI)	HYDROSTATIC TEST (PSI)
18	29.25	1.0	24.84	12 x 7/8 THRU	23-1/4	16.42	21.50	27.6	15.5	18.3	1262	IW6 AWWA-IP68	152:1	38	150 PSI	300 PSI
20	31.0	1.02	27.08	14 x 7/8 THRU	25-1/2	17.09	22.25	28.6	15.5	17.4	1537	IW6 AWWA-IP68	228:1	57		
24	42.00	1.02	31.57	16 x 7/8 THRU	30	21.06	26.37	35.4	21.6	21.8	3421	IW7 AWWA-IP68	384:1	96		
30	51.00	1.32	39.12	20 x 1-1/8 THRU	36-7/8	22.19	30.69	37.2	27.2	22.5	6135	IW9 AWWA-IP68	696:1	174		
36	60.00	1.45	46.00	24 x 1-1/8 THRU	43-3/4	25.81	34.75	42.3	27.2	27.7	8515	IW9 AWWA-IP68	928:1	232		

REV.	DESCRIPTION	DATE	APPROVED
1	RELEASED	11/13/15	ML
2	UPDATED FASTENER VIEW AND NOTES	2/19/2016	ML
3	ADDED ENCAPSULATION TO PLUG AND UPDATE TITLE BLOCK	4/5/2016	ML
4	UPDATED GEAR INFORMATION	5/11/2018	J CAPPER
5	316 SS STANDARD	2/19/2019	EPB
6	ADDED # OF TURNS TO OPEN AND CORRECTED GEARING INFORMATION. UPDATED # ADDED "L", "K", & "L" TO TABLE. REMOVED "14" AND "16" FROM DWG.	3/26/2019	CAW
7	ADDED TRI-MARKING NOTE	4/8/2019	J CAPPER

DRAWN	ML	DATE	12/17/2015
CHECKED	ML	DATE	11/13/2015
APPROVED		DATE	
M&H VALVE Division of McWane, Inc. <small>605 West 23rd Street, Anniston, Alabama 36201</small>			
TITLE:		8"-36" 100% PORT MJ Eccentric Plug Valve	
MATERIAL:		w/ ROTORK GEAR for Buried Service	
WEIGHT:	SEE TABLE	SIZE	DWG. NO.
		D	SUB910280T
REV	7	REV	7
<small>PROPRIETARY AND CONFIDENTIAL. THE INFORMATION CONTAINED HEREIN IS THE PROPERTY OF M&H VALVE CO. ANY REPRODUCTION IN PART OR AS A WHOLE WITHOUT THE WRITTEN PERMISSION OF M&H VALVE CO. IS PROHIBITED. DESIGN & INVENTION RIGHTS RESERVED.</small>			
			SHEET 1 OF 1