

*Optional Bypass Valve

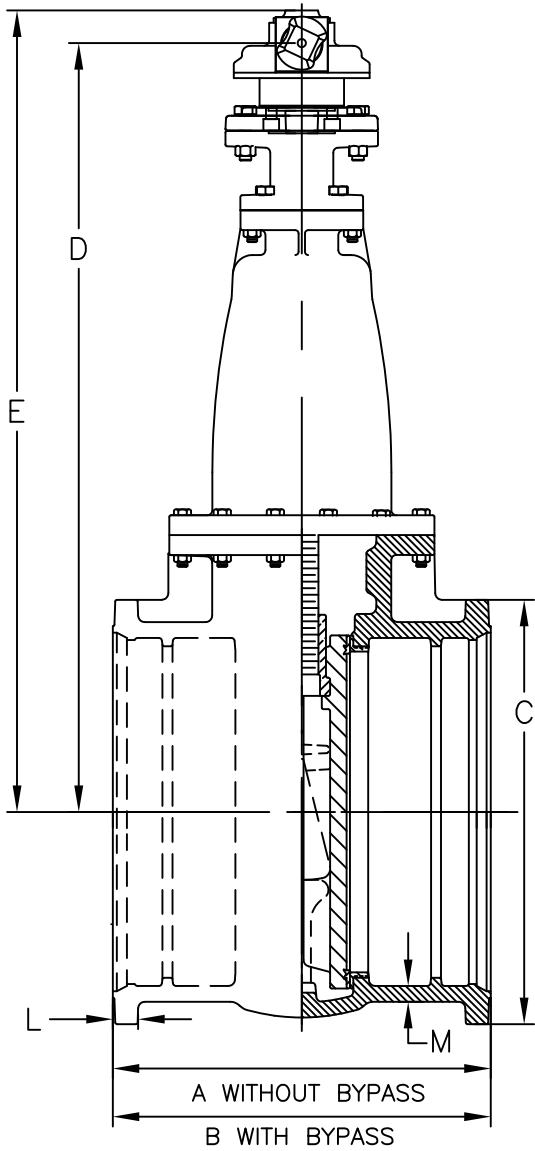
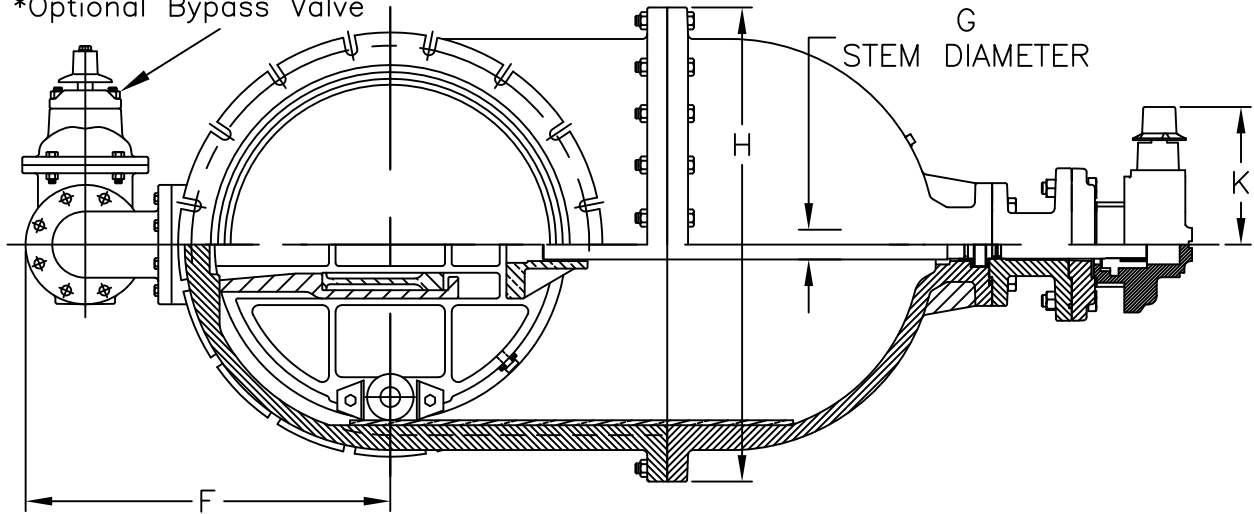

VALVE SIZE	14	16	18	20	24
A	7 1/4	9 1/8	9 1/4	10	16
B	15 1/2	13 3/4	14	16 3/4	21
C	20 1/4	22 1/2	24 3/4	27	32
D	37	41	47 7/8	51 1/2	58
E	39 1/4	43 1/4	50 3/8	54	60 1/2
F	19 1/4	20 1/2	22 1/2	24	28
G	1 7/8	1 7/8	2 1/8	2 1/8	2 1/2
H	23 5/8	25 3/4	27 3/4	32 7/8	35 3/4
K	9 1/4	9 1/4	10 1/4	10 1/4	10 1/4
L	1 5/16	1 7/16	1 7/16	1 1/2	1 5/8
M	7/8	7/8	15/16	1	1 1/8
URNS TO OPEN	90	104	174	192	228

*OPTIONAL BYPASS VALVE: (14"=2")(16"-20"=3")(24"=4")

M&H VALVE COMPANY
ANNISTON, ALABAMA
A DIVISION OF MCWANE INC.

DWN: TRIJ
DATE: 9/1/12
DWG. NO.
DD13

14" THRU 24"
DOUBLE DISC GATE VALVE
C500-MODEL 2613
(WITH BEVEL GEAR)(WITH BY-PASS)
(WITH ROLLERS, TRACKS, SCRAPPERS)
MJ X MJ

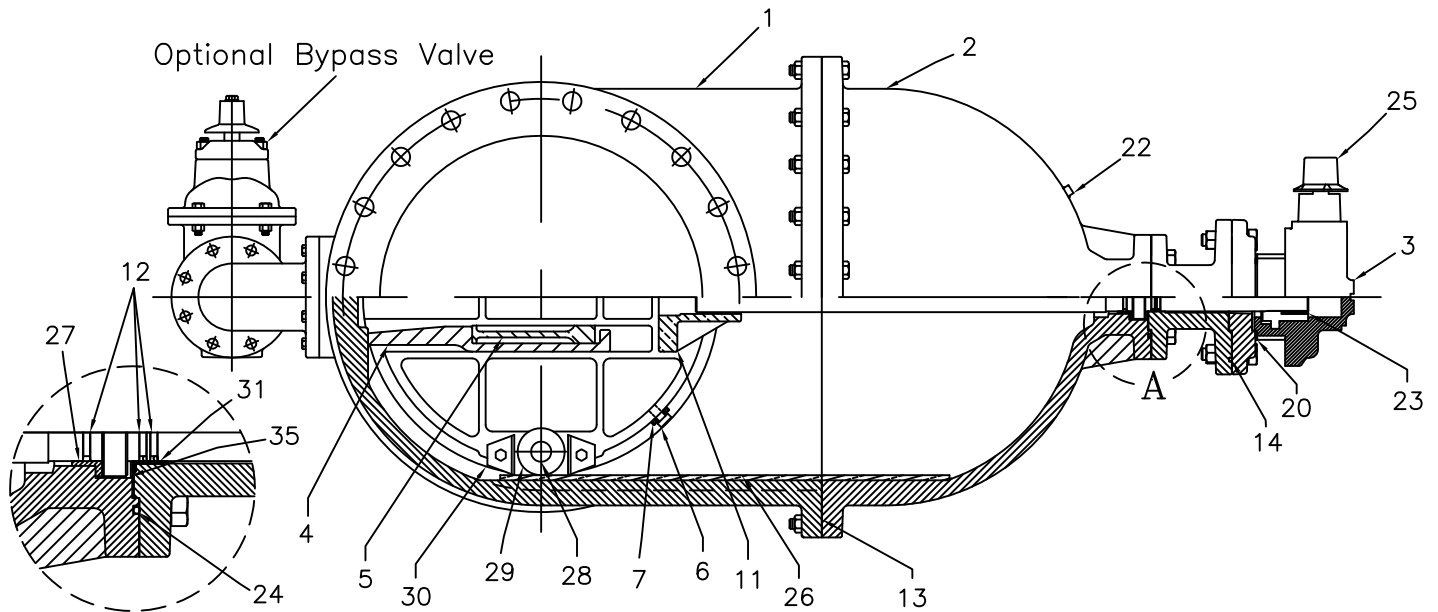

DETAIL
A

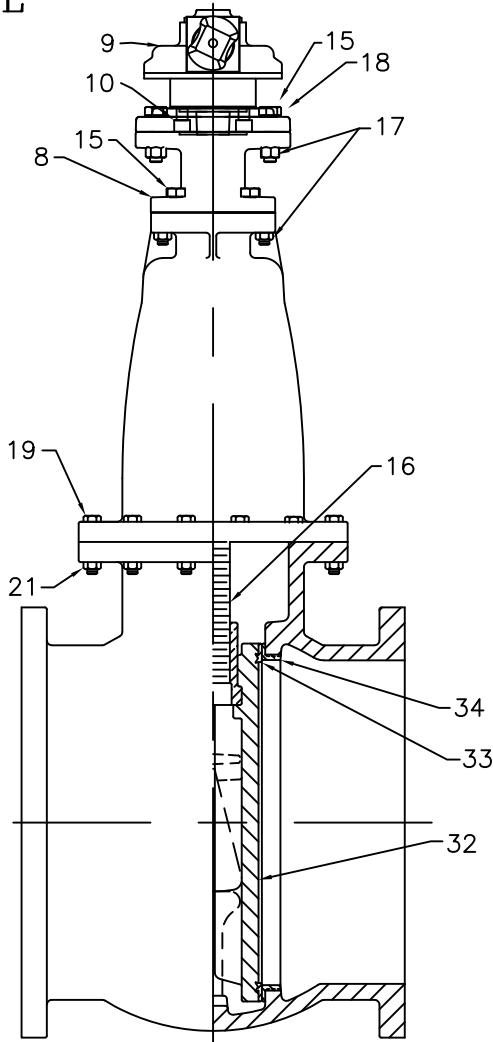

	QTY	DESCRIPTION	MATERIAL
	1	Body	Gray Iron, ASTM A126 Class B
	1	Bonnet / Cover	Gray Iron, ASTM A126 Class B
	1	Cap	-----
	2	Hook	Gray Iron, ASTM A126 Class B
	2	Wedge	Bronze, ASTM B584 C83600
	4	Gate Peg	Bronze, ASTM B584 C83600
	2	Strap	Bronze, ASTM B584 C83600
	1	Extension	Ductile Iron, ASTM A536 65-45-12
	1	Actuator 2:1 Actuator 3:1	14"-16" Only 18"-24" Only
	4	Socket Head Bolt	18-8 Stainless Steel
	1	Stem Nut	Bronze, ASTM B584 C83600
	3	O-ring-Stem	NBR
	2	O-ring-Cover	NBR
	1	O-ring-Extension	NBR
	4	Cap screw	Zinc Chromate Plated Steel
	1	Stem	Bronze, ASTM B584 C86700
	8	Nut	Zinc Chromate Plated Steel
	1	Adaptor Plate	Ductile Iron, ASTM A536 65-45-12
	18	Cap screw	Zinc Chromate Plated Steel
	1	Gasket-Actuator	Buna-N
	18	Nut	Zinc Chromate Plated Steel
	1	Pipe Plug	Steel
	1	Key	Steel
	1	O-ring-Cover Top	NBR
	1	Operating Nut	Ductile Iron, ASTM A536 65-45-12
	1	Track	Bronze, ASTM B584 C83600
	1	Bushing	Bronze, ASTM B584 C83600
	1	Shaft	Bronze, ASTM B584 C83600
	1	Roller	Bronze, ASTM B584 C83600
	2	Scraper	Bronze, ASTM B584 C83600
	1	Bushing	Bronze, ASTM B584 C83600
	2	Gate	Gray Iron, ASTM A126 Class B
	2	Gate Ring	Bronze, ASTM B584 C83600
	2	Case/Body Ring	Bronze, ASTM B584 C83600
	1	Thrust Washer	Delrin (18"-24")

*OPTIONAL BYPASS VALVE: (14"=2") (16"-20"=3") (24"=4")

M&H VALVE COMPANY
ANNISTON, ALABAMA
A DIVISION OF MCWANE INC.

DWN: TRIJ
DATE: 9/1/12
DWG. NO.
DD11

14" THRU 24"
DOUBLE DISC GATE VALVE
C500-MODEL 2613
(WITH BEVEL GEAR)(WITH BY-PASS)
(WITH ROLLERS, TRACKS, SCRAPPERS)
MATERIAL LIST / VALVE ASSEMBLY

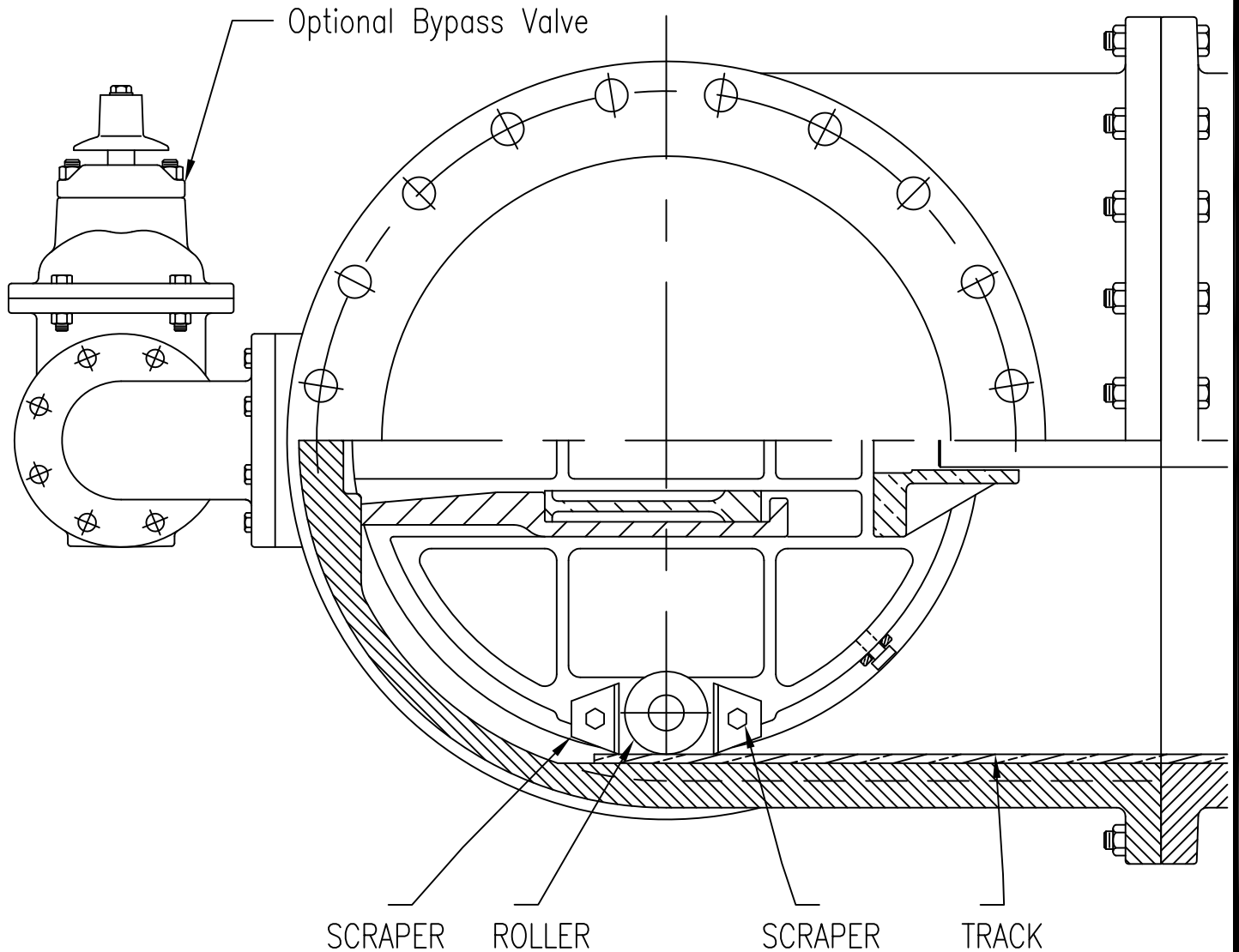

ROLLERS, TRACKS & SCRAPERS

Valves 14" and larger installed in a horizontal pipe line with their stems horizontal should be equipped with rollers, tracks, and scrapers, as illustrated. The rollers assist the travel of the gate assembly along tracks set into the valve body, retaining it in alignment, and promoting ease of operation, not otherwise possible. Scrapers are provided ahead of the rollers to clear the track of obstruction or foreign matter.

When required, rollers, tracks and scrapers are bronze.

M&H VALVE COMPANY
ANNISTON, ALABAMA
A DIVISION OF MCWANE INC.

DWN: TRIJ
DATE: 9/1/12
DWG. NO.
DD14

DOUBLE DISC GATE VALVES
C500-MODEL 2613
ROLLERS TRACKS & SCRAPERS
OVERVIEW

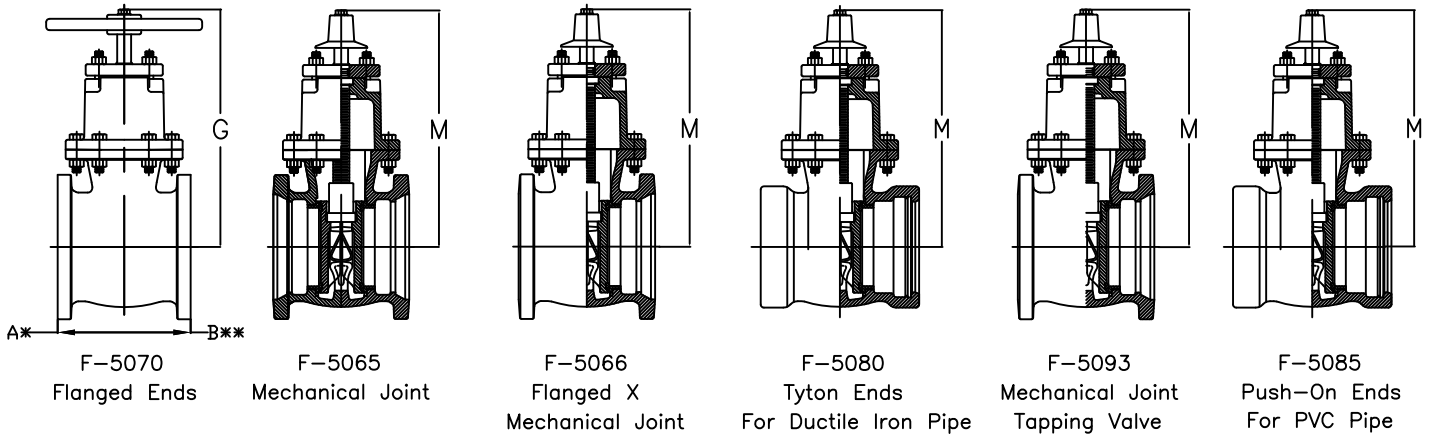

VALVE SIZE	A	B	G	M	TURNS TO OPEN	DIAM. OF STEM
2	7	—	10 1/4	10 1/4	5	7/8
2 1/4	7 1/2	—	10 1/4	10 1/4	5	7/8
2 1/2	7 1/2	—	11 3/8	11 3/8	6	7/8
3	8	—	12 1/4	12 1/2	7	7/8
4	9	—	14	14	15	1 1/8
5	10	—	15 1/2	15 1/2	18	1 1/8
6	10 1/2	—	18	18	21	1 1/4
8	11 1/2	—	22	22	27	1 3/8
10	13	—	25 5/8	25 5/8	33	1 1/2
12	14	—	29 1/8	29 1/8	39	1 1/2
14	15 3/4	23	36 1/2	39 3/4	45	1 7/8
16	17	23	40 3/4	43 1/2	52	1 7/8
18	19	24	43 1/4	46	58	2 1/8
20	20	24	47 1/4	50	64	2 1/8
24	23	28 1/2	55	56 3/4	76	2 1/2
30	25	32 1/2	64 3/4	66 1/2	63	2 3/4
36	27	36	75 3/8	77 3/8	75	3
42	34	34	—	—	88	3 1/2
48	45 1/2	45 1/2	—	—	100	4

TURNS TO OPEN ARE FOR VALVES WITHOUT GEARING

FLANGES ARE FACED AND DRILLED TO ANSI 125 POUND TEMPLATE, UNLESS OTHERWISE SPECIFIED

* WITHOUT BYPASS

** WITH BYPASS

M&H VALVE COMPANY
ANNISTON, ALABAMA
A DIVISION OF MCWANE INC.

DWN: TRIJ
DATE: 9/1/12
DWG. NO.
DD3

2" THRU 48"
DOUBLE DISC GATE VALVE
C500-MODEL 2613
GENERAL DIMENSIONS / INFORMATION