

1. FLOW MAY BE IN EITHER DIRECTION
2. VALVE SHAFT WILL MEET OR EXCEED AWWA C504 REQUIREMENTS
3. REFERENCE AWWA C504 FOR FLANGES AND DRILLING (ANSI 125)
4. 108 TURNS TO CLOSE
5. (44) 1 1/2" BOLTS ON EACH FLANGE (8 THREADED HOLES. 1 1/2"-6 UNC, 2 3/8" MIN DEPTH)
6. OPERATED BY AUMA GS200
7. RATED FOR 150psi WORKING PRESSURE

THIS DWG. AND ALL INFORMATION IS OUR PROPERTY AND SHALL NOT BE USED, COPIED, OR REPRODUCED WITHOUT WRITTEN CONSENT. DESIGN AND INVENTION RIGHTS RESERVED.



**M&H VALVE COMPANY**

A DIVISION OF McWANE INC.  
P.O. BOX 2088  
ANNISTON, ALABAMA 36202

**DRAWN:** EMW

**DATE:** 10/14/2021

**DWG. NO.**

BD48-F11-M1110-11110

48" AWWA C504 BUTTERFLY VALVE  
FLANGED ENDS - CL150  
AUMA GS200.3  
BURIED OPERATOR - OPEN LEFT

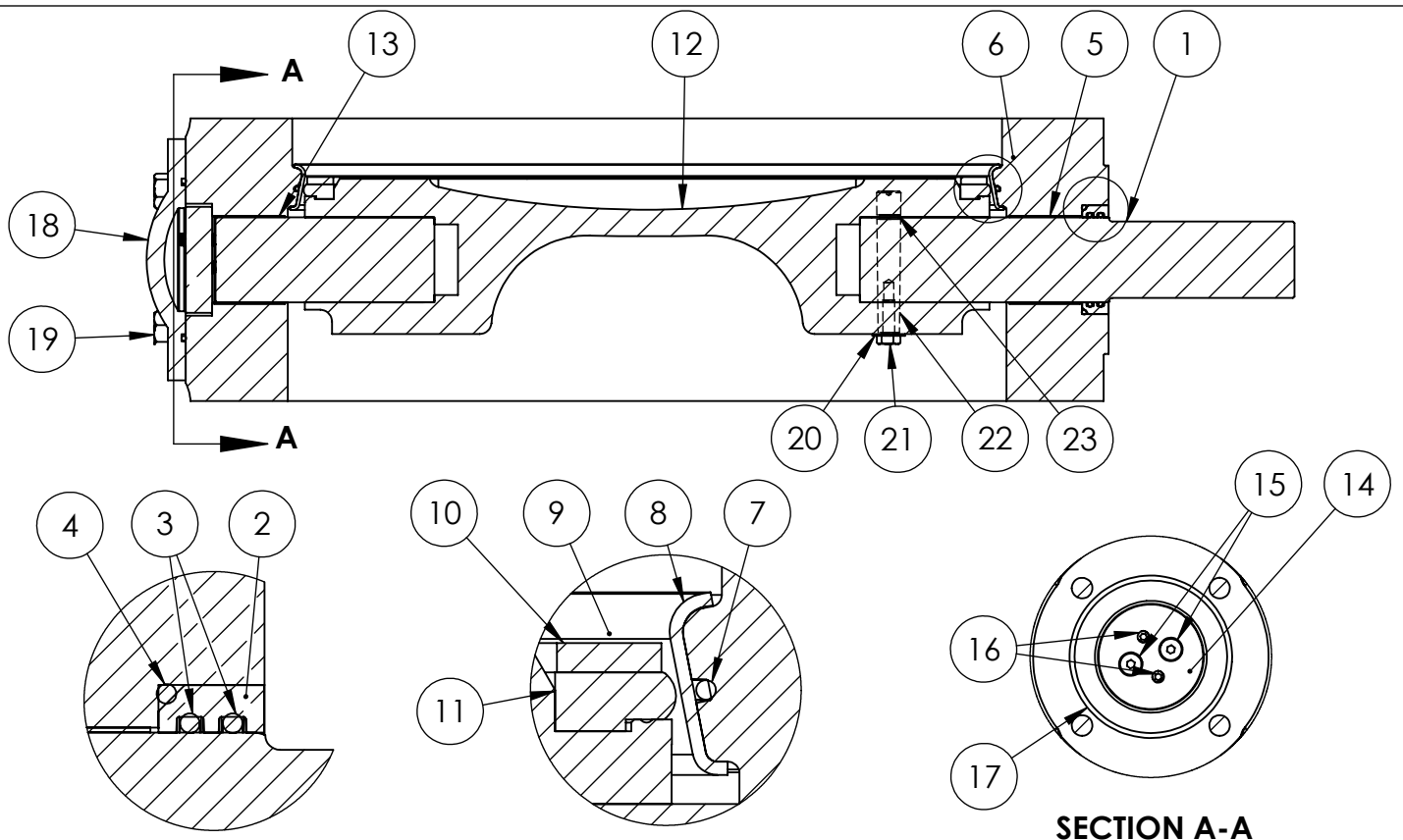

**SECTION A-A**

ITEM NO.	DESCRIPTION	MATERIAL
1	OPERATOR SHAFT	304 STAINLESS STEEL, ASTM A-276
2	SHAFT CARTRIDGE SEAL	BRONZE
3	CARTRIDGE SEAL O-RING (INSIDE)	BUNA-N
4	CARTRIDGE SEAL O-RING (OUTSIDE)	BUNA-N
5	UPPER BODY BUSHING	FIBERGLIDE BACKED WITH STAINLESS STEEL
6	VALVE BODY	DUCTILE IRON, ASTM A-536, GR 70-50-05
7	BODY O-RING	EPDM
8	BODY SEAT RING	316 STAINLESS STEEL, ASTM A-276
9	VANE BOLTS	18-8 STAINLESS STEEL
10	VANE CLAMP RING	304 STAINLESS STEEL, ASTM A-276
11	VANE SEAT RING	EPDM
12	VANE	DUCTILE IRON, ASTM A-536, GRADE 70-50-05
13	LOWER BODY BUSHING	FIBERGLIDE BACKED WITH STAINLESS STEEL
14	THRUST BEARING	BRONZE
15	BEARING CAP SCREW	18-8 STAINLESS STEEL
16	BEARING SET SCREW	18-8 STAINLESS STEEL
17	END COVER O-RING	EPDM
18	END COVER	DUCTILE IRON, ASTM A-536, GR 70-50-05
19	END COVER BOLTS	18-8 STAINLESS STEEL
20	TAPER PIN WASHER	416 STAINLESS STEEL
21	TAPER PIN BOLT	304 STAINLESS STEEL
22	TAPER PIN	416 STAINLESS STEEL
23	TAPER PIN O-RING	EPDM

THIS DWG. AND ALL INFORMATION IS OUR PROPERTY AND SHALL NOT BE USED, COPIED, OR REPRODUCED WITHOUT WRITTEN CONSENT. DESIGN AND INVENTION RIGHTS RESERVED.



**M&H VALVE COMPANY**  
 A DIVISION OF McWANE INC.  
 P.O. BOX 2088  
 ANNISTON, ALABAMA 36202

DWG. NO.  
 BBCC-F11-B0000-11110  
 DRAWN: EMW  
 DATE: 03/22/2021  
 REV. -

30"-54" AWWA C504 BUTTERFLY VALVE  
 FLANGED ENDS - RATED CL150  
 BODY SUB-ASM MATERIAL LIST