

M&H 5-1/4" MODEL 129 FIRE HYDRANT

ITEM#	DESCRIPTION	MATERIAL
1	WEATHER GUARD	MISC
2	FLAT HEAD BOLT, 1/2"-13 x 2"	18-8 SS
3	OP NUT	ECO BRASS
4	HOLD DOWN NUT O-RING	BUNA-N
5	UPPER ROD	STAINLESS STEEL
6	BONNET	CAST IRON
7	BONNET STEM O-RING	BUNA-N
8	NOZZLE SECTION	CAST IRON
9	CLEVIS PIN / CLIP	410 SS / 18-8 SS
10	BREAK FLANGE BOLTS, 5/8"-11 x 4"	ZINC PLATED STEEL
11	STAND PIPE UPPER FLANGE	DUCTILE IRON
12	SAFETY BREAK FLANGES	CAST IRON
13	LOWER STEM	STAINLESS STEEL
14	SHOE BOLTS, 5/8"-11 x 3 1/2"	18-8 SS
15	DRAIN VALVE FACING RIVETS	ALUMINUM
16	SHOE NUTS, 5/8"-11	18-8 SS
17	SEAT RING UPPER O-RING	BUNA-N
18	RETAINING RING	ECO BRASS
19	MAIN VALVE RUBBER	EPDM
20	LOWER VALVE PLATE	CAST IRON
21	SHOE	DUCTILE IRON
22	LOCK WASHER	18-8 SS
23	SEAT RING LOWER O-RING	BUNA-N
24	MAIN VALVE SEAT RING	BRONZE
25	DRAIN HOLE BUSHING	BRONZE
26	MAIN VALVE O-RING	BUNA-N
27	RETAINING RING O-RING	BUNA-N
28	LOWER STEM PIN	18-8 SS
29	DRAIN VALVE FACINGS	EPDM
30	STAND PIPE LOWER FLANGE	DUCTILE IRON
31	MAIN VALVE UPPER PLATE	BRONZE
32	STAND PIPE	DUCTILE IRON
33	BREAK FLANGE NUTS, 5/8"-11	ZINC PLATED STEEL
34	NOZZLE / STAND PIPE O-RING	BUNA-N
35	BREAK COUPLING	STAINLESS STEEL
36	CHAIN ASSEMBLY	ZINC PLATED STEEL
37	PUMPER NOZZLE SET SCREWS	18-8 SS
38	PUMPER CAP	CAST IRON
39	PUMPER CAP GASKET	RUBBER ASTM D2000
40	PUMPER NOZZLE O-RING	BUNA-N
41	BONNET NUT, 1/2"-13	ZINC PLATED STEEL
42	BONNET BOLT, 1/2"-13 x 2 1/4"	ZINC PLATED STEEL
43	OP NUT THRUST BEARING	ACETAL
44	HOLD DOWN NUT SET SCREW	18-8 SS
45	HOLD DOWN NUT	ECO BRASS

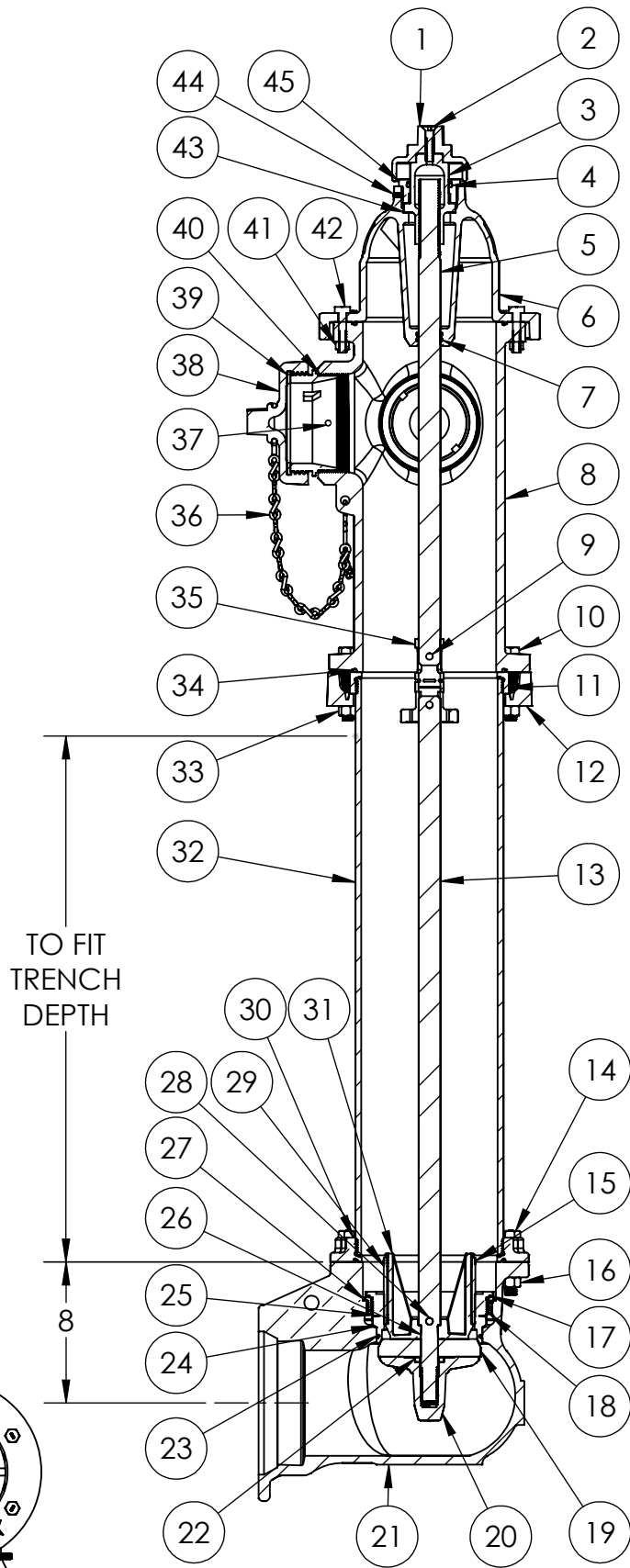

MAIN VALVE SIZES AVAILABLE: 5-1/4"
14-15 TURNS TO OPEN

MEET OR EXCEEDS AWWA C502
250 PSI WORKING PRESSURE AWWA
200 PSI WORKING PRESSURE UL/FM
500 PSI HYDROSTATIC TEST PRESSURE

HYDRANT SHOE OUTLETS AVAILABLE:
6" MJ: 5-1/4"
6" FLG: 5-1/4"

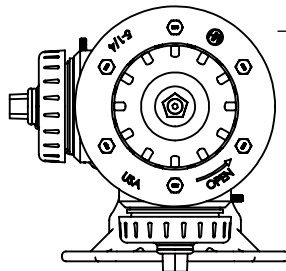

THIS DWG. AND ALL INFORMATION IS OUR PROPERTY AND SHALL NOT BE USED, COPIED, OR REPRODUCED WITHOUT WRITTEN CONSENT. DESIGN AND INVENTION RIGHTS RESERVED.



M&H VALVE COMPANY
A DIVISION OF McWANE INC.
P.O. BOX 2088
ANNISTON, ALABAMA 36202

DRAWN: CM
DATE: 04/18/2022
DWG. NO.
H1S5-21-N2-L211-00

M&H MODEL 129S
FIRE HYDRANT - DOUBLE PUMPER